

SERVICE MANUAL

A-X5000/A-X3000/A-X1000

DC Integrated Stereo Amplifier

NOTES

- PC boards shown viewed from parts side.
- Parts marked with *require longer delivery time.
- The mechanical parts with no reference number or no parts number in the exploded views are not supplied.
- As regards the resistors and capacitors, refer to the circuit diagrams contained in this manual.
- Δ Parts marked with this sign are safety critical components. They must always be replaced with identical components refer to the appropriate parts list and ensure exact replacement.

* Dolby noise reduction manufactured under license from Dolby Laboratories Licensing Corporation. "DOLBY" and the double-D symbol $\square\square$ are trademarks of Dolby Laboratories Licensing Corporation.

1. SPECIFICATIONS

A-X5000

Continuous Power Output:

RMS: 75 W + 75 W
(20 – 20,000 Hz, 8 ohms, THD
0.009 %)

100 W + 100 W
(20 – 20,000 Hz, 4 ohms, THD
0.025 %)

DIN (1 kHz): 85 W + 85 W (8 ohms)
120 W + 120 W (4 ohms)

Dynamic Power Output (EIA)

100 W + 100 W (8 ohms)
150 W + 150 W (4 ohms)

Total Harmonic Distortion

0.007 % (1 kHz, 8 ohms,
continuous rated power output)
0.009 % (20 – 20,000 Hz, 8 ohms,
continuous rated power output)
0.01 % (1 kHz, 4 ohms,
continuous rated power output)
0.025 % (20 – 20,000 Hz, 4 ohms,
continuous rated power output)

Input Sensitivity/Impedance:

Phono MM/MC : 2.5 mV
(47 kohms)/250 μ V (100 ohms)
CD, TUNER, AUX, TAPE 1/2/3 :
150 mV/30 kohms

Signal-to Noise Ratio (IHF-A):

Phono MM/MC: 80 dB (2.5 mV/
67 dB (250 μ V)

Line : 101 dB

Output Level/Impedance : TAPE 1/DAT,

TAPE2, TAPE3 : 150 mV/1 kohms

Frequency Response : PHONO :

20 – 20,000 Hz, \pm 0.5 dB (RIAA)
CD, TUNER, AUX, TAPE 1/2/3 :
5 – 100,000 Hz, -3dB

Tone Control : Bass : \pm 10 dB (100 Hz)

Treble : \pm 10 dB (10 kHz)

Loudness Contour : +8/+6 dB at

100 Hz/10 kHz

Subsonic Filter : 15 Hz (6 dB/oct.)

Muting : -20 dB

Power Requirements/

Power Consumption:

115/230 V AC, 50/60 Hz, 700 W
(General Export)
120 V AC, 60 Hz, 330 W (USA)
120 V AC, 60 Hz, 630 VA (Canada)
220 V AC, 50 Hz, 700 W (Europe)
240 V AC, 50 Hz, 860 W
(UK/Australia)

Dimension (W x H x D):

435 x 155 x 354 mm

Weight (net) : 10.5 kg

Improvements may result in feature and
specification change without notice.

A-X3000/A-X1000

Continuous Power Output:

A-X3000:

RMS: 60 W + 60 W
(20 – 20,000 Hz, 8 ohms, THD
0.02 %)

75 W + 75 W
(20 – 20,000 Hz, 4 ohms, THD
0.04 %)

DIN (1 kHz): 72 W + 72 W (8 ohms)
100 W + 100 W (4 ohms)

A-X1000:

RMS: 40 W + 40 W
(20 – 20,000 Hz, 8 ohms, THD
0.02 %)

50 W + 50 W
(20 – 20,000 Hz, 4 ohms, THD
0.04 %)

DIN (1 kHz) : 55 W + 55 W (8 ohms)
72 W + 72 W (4 ohms)

Dynamic Power Output (EIA)

A-X3000 : 78 W + 78 W (8 ohms)
115 W + 115 W (4 ohms)

A-X1000 : 58 W + 58 W (8 ohms)
90 W + 90 W (4 ohms)

Total Harmonic Distortion

A-X3000 : 0.008 % (1 kHz,
8 ohms, continuous rated power
output)

0.02 % (20 – 20,000 Hz, 8 ohms,
continuous rated power output)

0.015 % (1 kHz, 4 ohms,
continuous rated power output)

0.04 % (20 – 20,000 Hz, 4 ohms,
continuous rated power output)

A-X1000 : 0.0085 % (1 kHz,

8 ohms, continuous rated power
output)

0.02 % (20 – 20,000 Hz, 8 ohms,
continuous rated power output)

0.017 % (1 kHz, 4 ohms,
continuous rated power output)

0.04 % (20 – 20,000 Hz, 4 ohms,
continuous rated power output)

Input Sensitivity/Impedance:

Phono : 2.5mV/47 kohms CD,
TUNER, AUX, TAPE1/2 :
150 mV/30 kohms
MIC : 0.6mV/47 kohms

Signal-to Noise Ratio (IHF-A):

Phono: 72 dB (2.5 mW)
Line : 101 dB

Output Level/Impedance : TAPE 1/DAT,

TAPE2 : 150 mV/1 kohms

Frequency Response : PHONO :

20 – 20,000 Hz, \pm 0.5 dB (RIAA)
CD, TUNER, AUX, TAPE 1/2 :
5 – 100,000 Hz, -3dB

Tone Control : Bass : \pm 10 dB (100 Hz)

Treble : \pm 10 dB (10 kHz)

Loudness Contour : +8/+6 dB at

100 Hz/10 kHz

Subsonic Filter (A-X3000 only):

15 Hz (6 dB/oct.)

Muting (A-X300 only): -20 dB

Power Requirements/

Power Consumption:

115/230 V AC, 50/60 Hz, 550 W
(A-X3000), 410 W (A-X1000)

(General Export)

120 V AC, 60 Hz, 240 W
(A-X3000)

180 W (A-X1000)(USA)

120 V AC, 60 Hz, 460 VA

(A-X3000), 340 VA (A-X1000)
(Canada)

220 V AC, 50 Hz, 550 W

(A-X3000),

410 W (A-X1000)(Europe)

240 V AC, 50 Hz, 630 W

(A-X3000),

480 W (A-X1000)(UK/Australia)

Dimension (W x H x D):

435 x 155 x 354 mm

Weight (net) : 9.0 kg (A-X3000)

7.8 kg (A-X1000)

Improvements may result in feature and
specification change without notice.

2. ADJUSTMENT AND CHECKS

AMPLIFIER SECTION

Condition

Power requirements : 120 V AC, 60 Hz (U.S./Canada)
 220 V AC, 50 Hz (Europe)
 115 V/230 V AC, 60 Hz/50 Hz
 (General Export)
 240 V AC, 50 Hz (AUS. UK)

Input : No signal
 Output load : 8 ohms

● Idling current

1. Set the Power switch to ON and wait for 5 minutes for preheating.
2. Connect a DVM (Digital Voltage Meter) across R343 (0.22 ohms x 2 = 0.44 ohms).

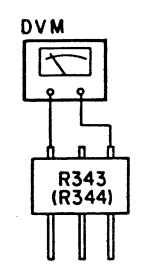

3. Adjust VR301 (L CH) so that the DVM reads 9 mV ± 1.5 mV (A-X1000/A-X3000) or 6 mV ± 1.5 mV (A-X5000).
4. Connect the DVM across R344 (0.22 ohms x 2 = 0.44 ohms).
5. Adjust VR302 (R CH) so that the DVM reads 9 mV ± 1.5 mV (A-X1000/A-X3000) or 6 mV ± 1.5 mV (A-X5000).

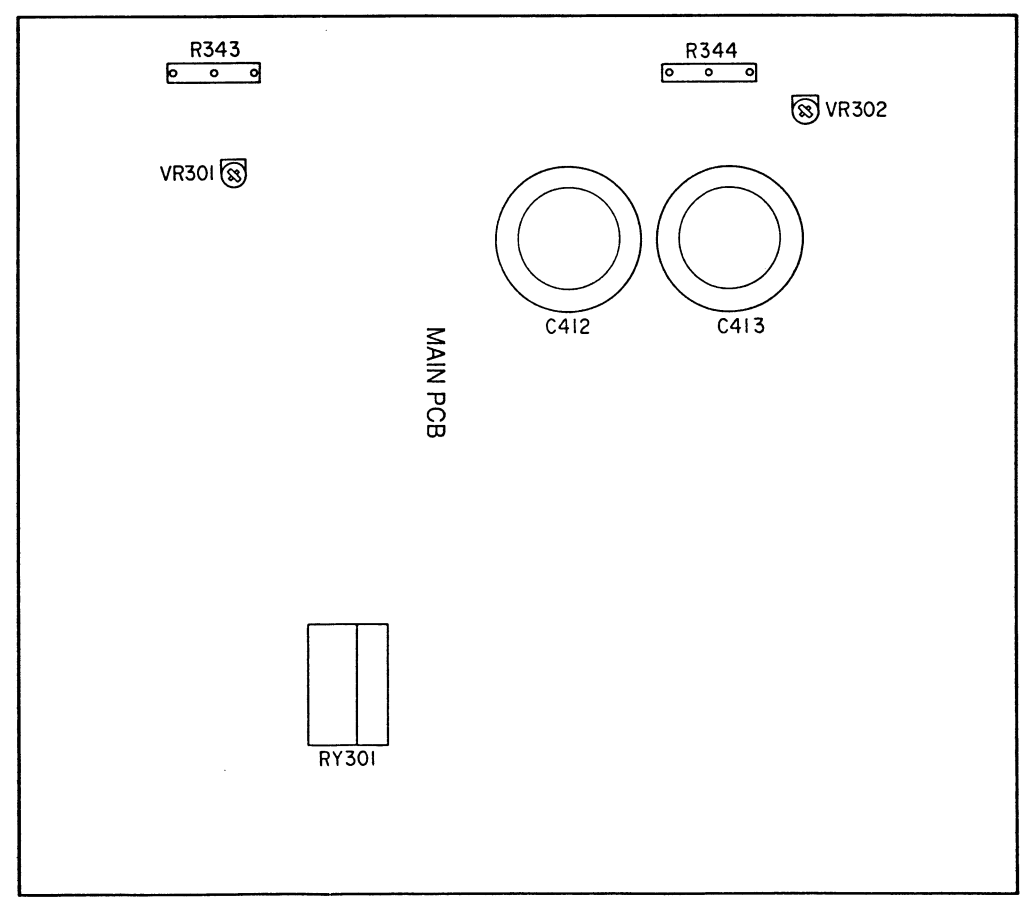

3. BLOCK DIAGRAM

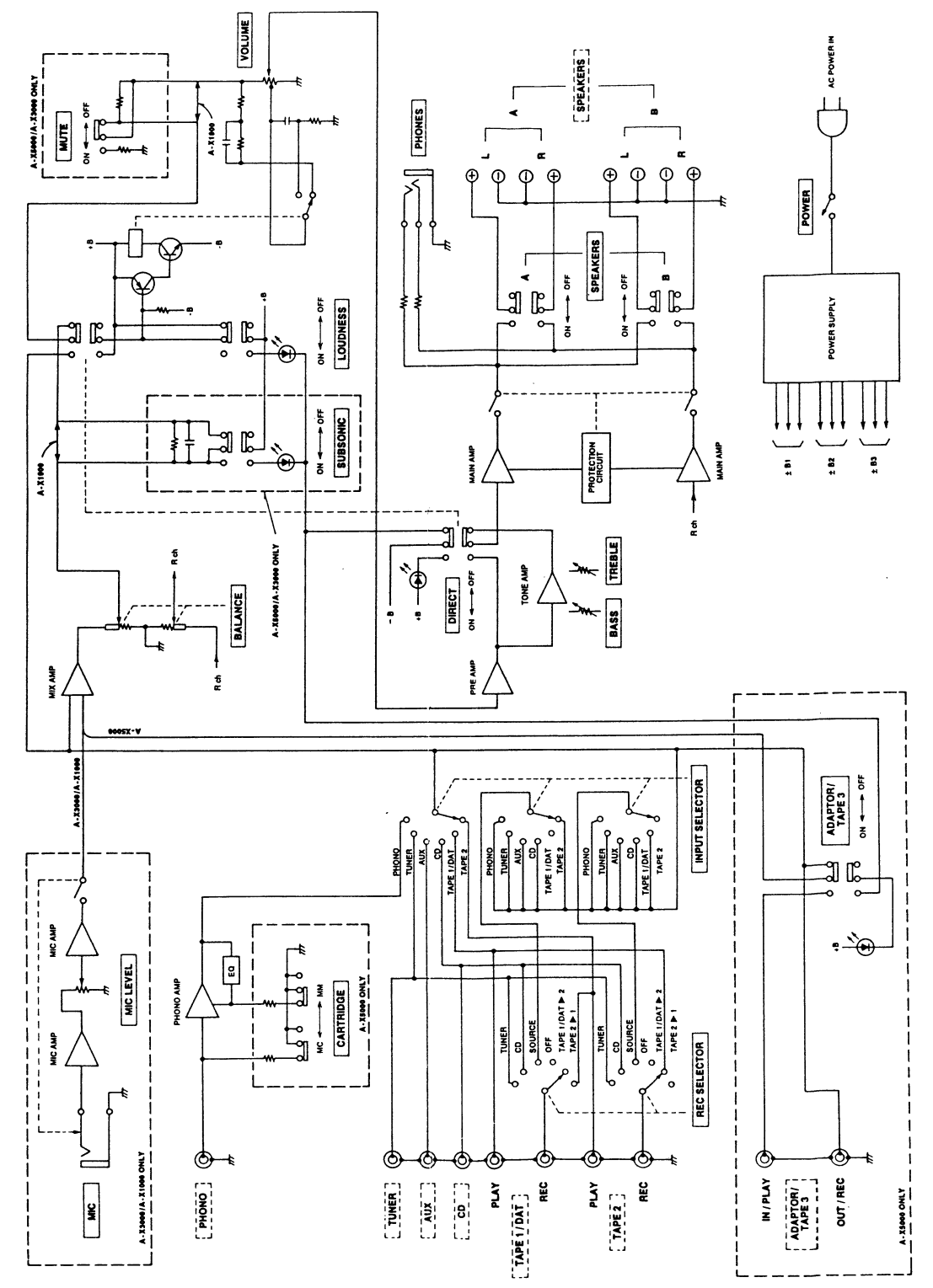

4. EXPLODED VIEW AND PARTS LIST

EXPLODED VIEW-1

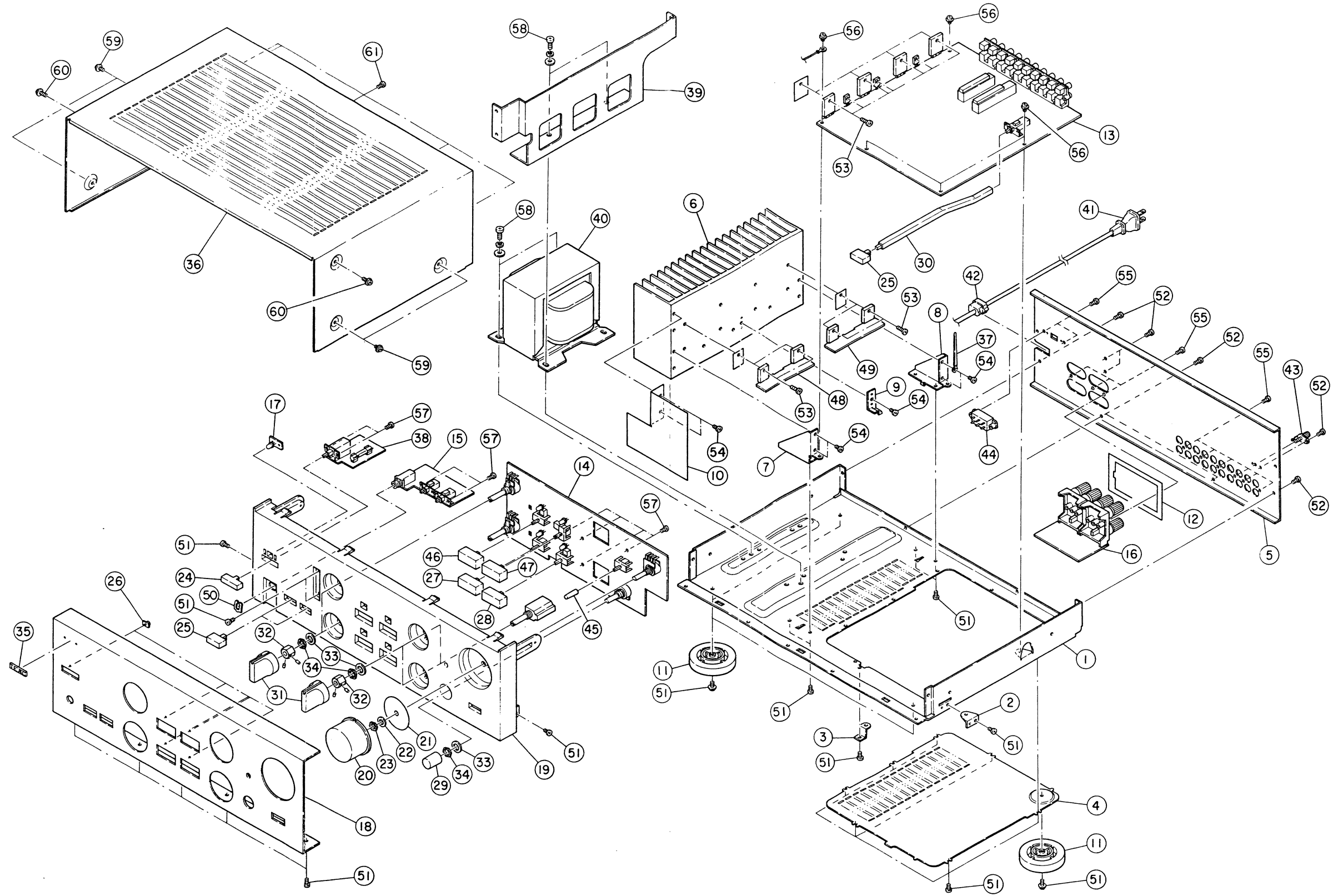

EXPLODED VIEW-I (A-X5000)

REF.NO.	PARTS NO.	DESCRIPTION	REMARKS
1- 1	*9260135501	MAIN CHASSIS	
1- 2	*9260133800	PCB HOLDER (C)	
1- 3	*9260134000	PCB HOLDER (A)	
1- 4	*9260135200	BOTTOM COVER	
1- 5	*9260136501	REAR PANEL [EXCEPT-GE]	
	*9260139501	REAR PANEL [GE]	
1- 6	*9260135600	HEAT SINK	
1- 7	*9260133600	HEAT SINK HOLDER (L)	
1- 8	*9260133700	HEAT SINK HOLDER (R)	
1- 9	*9260133900	PCB HOLDER (B)	
1-10	*9260136200	SHILED PLATE (B)	
1-11	*9260113901	FOOT ASSY	
1-12	*9260137000	REAR PANEL SPACER	
1-13	*9145084141	MAIN PCB ASSY [E-D, E-DF]	Ref. pages 12 & 14
	*9145084151	MAIN PCB ASSY [EXCEPT E-D/DF]	Ref. pages 12 & 14
1-14	*9145086101	FRONT PCB ASSY [E-D, E-DF]	Ref. pages 13 & 14
	*9145086111	FRONT PCB ASSY [EXCEPT E-D/DF]	Ref. pages 13 & 14
1-15	*9145086301	PHONE JACK PCB ASSY [E-D,E-DF]	Ref. pages 13 & 14
	*9145086311	PHONE JACK PCB ASSY [EXCEPT E-D/DF]	Ref. pages 13 & 14
1-16	*9145086401	SPEAKER TM PCB ASSY [E-D,E-DF]	Ref. pages 13 & 14
	*9145086411	SPEAKER TM PCB ASSY [US,C,GE,E,A,E-F]	Ref. pages 13 & 14
	*9145086420	SPEAKER TM PCB ASSY [UK]	Ref. pages 13 & 14
1-17	*9145086500	POWER LED PCB ASSY	Ref. pages 13 & 14
1-18	*9260136701	FRONT PANEL C	
1-19	*9260136801	FRONT BASE	
1-20	*9260135700	VOLUME KNOB ASSY	
1-21	*9260139400	EARTH SHILED PLATE	
1-22	*9294005500	WASHER, VR (ZN7)	
1-23	*9781800700	NUT, VR (ZN7)	
1-24	*9260132900	POWER BUTTON	
1-25	*9260134400	SPEAKER BUTTON	
1-26	*9260134100	LED LENS	
1-27	*9260138700	PUSH BUTTON A (LOUDNESS)	
1-28	*9260139700	PUSH BUTTON A (SUBSONIC)	
1-29	*9260134500	BALANCE KNOB	
1-30	*9260136401	MM/MC LINKAGE	
1-31	*9260136000	SELECTOR KNOB	
1-32	*9260139800	KNOB ADAPTOR ASSY	
2-33	*9294005600	WASHER, VR (ZN9)	
2-34	*9781800900	NUT, VR (ZN9)	
1-35	*5801413200	NAME PLATE, TEAC	
1-36	*9260136600	BONNET	
1-37	*9788823059	WIRE CLAMPER	
1-38	△*9145086200	POWER SW PCB ASSY [E-D,E-F/DF,E]	Ref. pages 13 & 14
	△*9145086210	POWER SW PCB ASSY [US,C,GE]	Ref. pages 13 & 14
	△*9145086220	POWER SW PCB ASSY [UK,A]	Ref. pages 13 & 14
1-39	*9260136901	TRANS HOLDER	
1-40	△*9125085000	POWER TRANS. [US,C]	
	△*9125085200	POWER TRANS. [E-D,E-DF]	
	△*9125085300	POWER TRANS. [GE]	
	△*9125085700	POWER TRANS. [UK,A]	
	△*9125085900	POWER TRANS. [E,E-F]	
1-41	△*5350010700	CORD,AC UL SPT-2 [US,C,GE]	
	△*9109025701	AC CORD, CEE CLASS2 [E-D/F/DF,E]	
	△*9109025901	AC CORD [UK]	
	△*9109026000	AC CORD [A]	

[US]:U.S.A. [C]:CANADA [E-D]:GERM,SWEDEN,NORWAY,DENMARK [GE]:GENERAL EXPORT [UK]:U.K. [A]:AUSTRALIA
[E]:SWITZLD,NETHLD,GREECE,AUSTRIA,SPAIN,ITALY,TURKEY [E-F]:FRANCE,BELGIUM [E-DF]:FINLAND

Parts marked with *require longer delivery time.

EXPLODED VIEW-I (A-X5000)

REF.NO.	PARTS NO.	DESCRIPTION	REMARKS
1-42	*9121000101	BUSHING, #2271	
1-43	J101 *9143289000	GND TERMINAL, YKD41-0004	
1-44	S602△*5300918600	VOLTAGE SELECTOR,SDKGA4 [GE]	
1-45	*9260134300	PUSH BUTTON B	
1-46	*9260139600	PUSH BUTTON A (ADAPTOR)	
1-47	*9260134200	PUSH BUTTON A (SOURCE)	
1-48	*9145084200	TR., PCB-1 ASSY	Ref. pages 13 & 14
1-49	*9145084300	TR., PCB-2 ASSY	Ref. pages 13 & 14
1-50	*5143248000	MOUNTING PLATE A	
1-51	*9783203008	SCREW, BTT-S M3X8	
1-52	*9783233008	SCREW, BTT-S M3X8 (BLK)	
1-53	*9783213012	SCREW, BTT-B M3X12	
1-54	*9783213008	SCREW, BTT-B M3X8	
1-55	*9783613008	SCREW, BTT-P M3X8 (BLK)	
1-56	*9783103006	SCREW, CAP-S M3X6	
1-57	*9783603008	SCREW, BTT-P M3X8	
1-58	*9783295010	SCREW, BTB-S M5X10	
1-59	*9783053006	SCREW, CAP-S M3X6 (BLK)	
1-60	*9783413010	SCREW, CAP-P M3X10 (BLK)	
1-61	*9783593008	SCREW, C-TITE M3X10 (NI-BLK)	

INCLUDED ACCESSORIES

REF.NO.	PARTS NO.	DESCRIPTION	REMARKS
	*9101384300	OWNER'S MANUAL(M) A-X3000/A-X1000	
	*9101384600	OWNER'S MANUAL(M) A-X5000	

[US]:U.S.A. [C]:CANADA [E-D]:GERM,SWEDEN,NORWAY,DENMARK [GE]:GENERAL EXPORT [UK]:U.K. [A]:AUSTRALIA
[E]:SWITZLD,NETHLD,GREECE,AUSTRIA,SPAIN,ITALY,TURKEY [E-F]:FRANCE,BELGIUM [E-DF]:FINLAND

Parts marked with *require longer delivery time.

EXPLODED VIEW-2

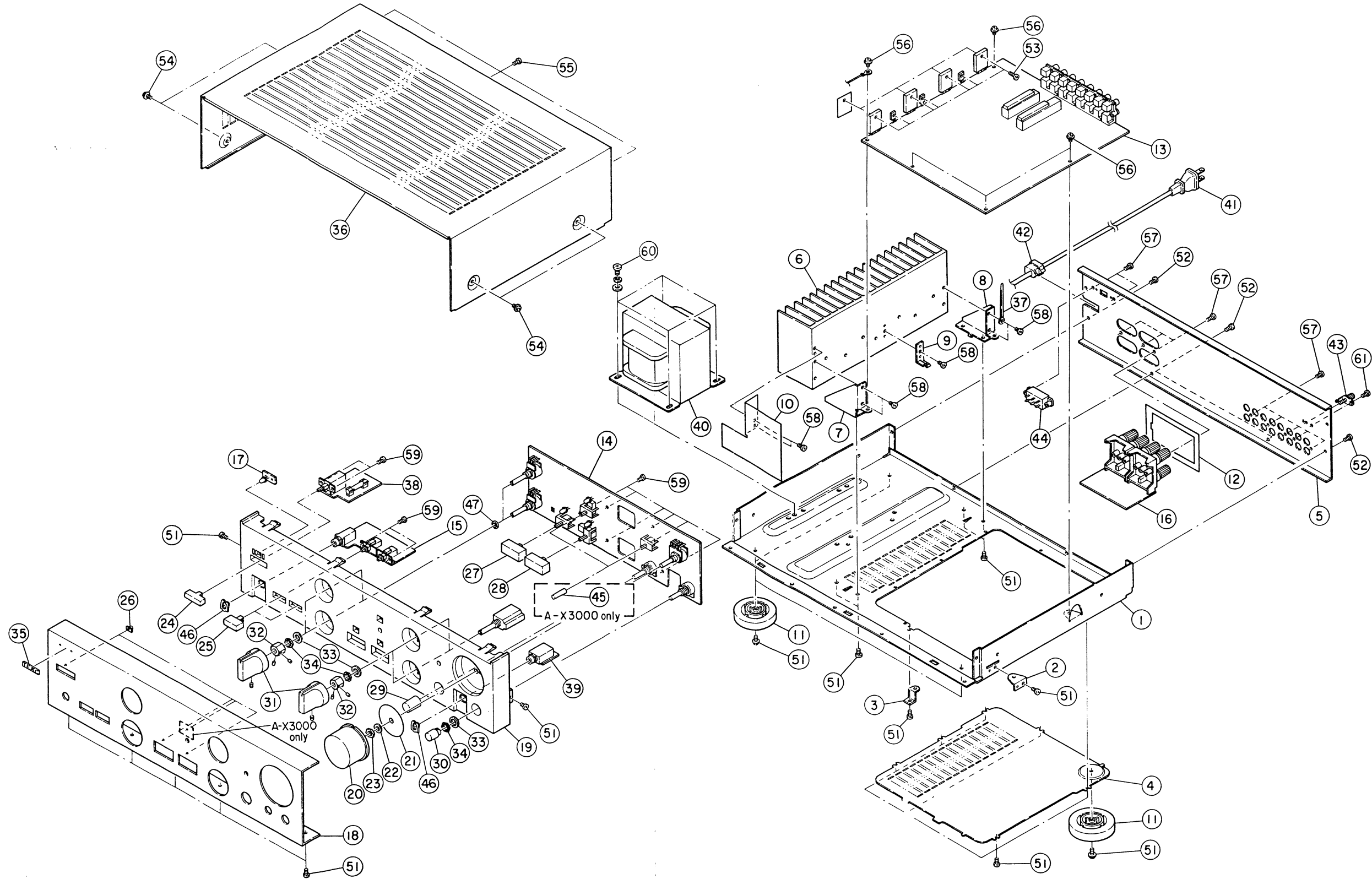

EXPLODED VIEW-2 (A-X3000/A-X1000)

REF.NO.	PARTS NO.	DESCRIPTION	REMARKS
2- 1	*9260135501	MAIN CHASSIS	
2- 2	*9260133800	PCB HOLDER (C)	
2- 3	*9260134000	PCB HOLDER (A)	
2- 4	*9260135200	BOTTOM COVER	
2- 5	*9260136301	REAR PANEL [GE]	
	*9260135302	REAR PANEL (A-X1000) [EXCEPT GE]	
	*9260153601	REAR PANEL (A-X3000) [EXCEPT GE]	
2- 6	*9260131200	HEAT SINK (A-X1000)	
	*9260131301	HEAT SINK (A-X3000)	
2- 7	*9260133600	HEAT SINK HOLDER (L)	
2- 8	*9260133700	HEAT SINK HOLDER (R)	
2- 9	*9260133900	PCB HOLDER (B)	
2-10	*9260136101	SHILED PLATE (A)	
2-11	*9260113901	FOOT ASSY,	
2-12	*9260137000	REAR PANEL SPACER	
2-13	*9145084100	MAIN PCB ASSY (A-X1000) [E-D,E-DF]	Ref. pages 12 & 15
	*9145084110	MAIN PCB ASSY (A-X1000) [EXCEPT E-D/DF]	Ref. pages 12 & 15
	*9145084120	MAIN PCB ASSY (A-X3000) [E-D,E-DF]	Ref. pages 12 & 15
	*9145084130	MAIN PCB ASSY (A-X3000) [EXCEPT E-D/DF]	Ref. pages 12 & 15
2-14	*9145085101	FRONT PCB ASSY (A-X1000) [E-D,E-DF]	Ref. pages 13 & 16
	*9145085111	FRONT PCB ASSY (A-X1000) [EXCEPT E-D/DF]	Ref. pages 13 & 16
	*9145085121	FRONT PCB ASSY (A-X3000) [E-D,E-DF]	Ref. pages 13 & 16
	*9145085131	FRONT PCB ASSY (A-X3000) [EXCEPT E-D/DF]	Ref. pages 13 & 16
2-15	*9145085401	PHONE JACK PCB ASSY [E-D,E-DF]	Ref. pages 13 & 17
	*9145085411	PHONE JACK PCB ASSY [EXCEPT E-D/DF]	Ref. pages 13 & 17
2-16	*9145085501	SPEAKER.TM.PCB ASSY [E-D,E-DF]	Ref. pages 13 & 17
	*9145085511	SPEAKER.TM.PCB ASSY [US,C,GE,A,E,E-F]	Ref. pages 13 & 17
	*9145085521	SPEAKER.TM.PCB ASSY [UK]	Ref. pages 13 & 17
2-17	*9145085600	POWER LED PCB ASSY	Ref. pages 13 & 17
2-18	*9260134901	FRONT PANEL (A) (A-X1000)	
	*9260135001	FRONT PANEL (B) (A-X3000)	
2-19	*9260135901	FRONT BASE	
2-20	*9260135700	VOLUME KNOB ASSY	
2-21	*9260139400	EARTH SHILED PLATE	
2-22	*9294005500	WASHER, VR (ZN7)	
2-23	*9781800700	NUT, VR (ZN7)	
2-24	*9260132900	POWER BUTTON	
2-25	*9260134400	SPEAKER BUTTON	
2-26	*9260134100	LED LENS	
2-27	*9260138700	PUSH BUTTON A (LOUDNESS)	
2-28	*9260134200	PUSH BUTTON A (SOURCE)	
2-29	*9260134500	BALANCE KNOB	
2-30	*9260134600	MIC KNOB	
2-31	*9260136001	SELECTOR KNOB	
2-32	*9260139800	KNOB ADAPTOR ASSY	
2-33	*9294005600	WASHER, VR (ZN9)	
2-34	*9781800900	NUT, VR (ZN9)	
2-35	*5801413200	NAME PLATE, TEAC	
2-36	*9260135100	BONNET	
2-37	*9788823059	WIRE CLAMPER	
2-38	△*9145085300	POWER SW PCB ASSY (A-X1000) [US,C]	Ref. pages 13 & 16
	△*9145085310	POWER SW PCB ASSY (A-X1000) [E,E-D/F/DF]	Ref. pages 13 & 16
	△*9145085320	POWER SW PCB ASSY (A-X1000) [GE]	Ref. pages 13 & 16
	△*9145085330	POWER SW PCB ASSY (A-X1000) [UK,A]	Ref. pages 13 & 16

[US]:U.S.A. [C]:CANADA [E-D]:GERM,SWEDEN,NORWAY,DENMARK [GE]:GENERAL EXPORT [UK]:U.K. [A]:AUSTRALIA [E]:SWITZLD,NETHLDS,GREECE,AUSTRIA,SPAIN,ITALY,TURKEY [E-F]:FRANCE,BELGIUM [E-DF]:FINLAND

Parts marked with *require longer delivery time.

EXPLODED VIEW-2 (A-X3000/A-X1000)

REF.NO.	PARTS NO.	DESCRIPTION	REMARKS
2-38	△*9145085340	POWER SW PCB ASSY (A-X3000) [US,C]	Ref. pages 13 & 16
	△*9145085350	POWER SW PCB ASSY (A-X3000) [E,E-D/F/DF]	Ref. pages 13 & 16
	△*9145085360	POWER SW PCB ASSY (A-X3000) [GE]	Ref. pages 13 & 16
	△*9145085370	POWER SW PCB ASSY (A-X3000) [UK,A]	Ref. pages 13 & 16
2-39	*9145085200	MIC. J PCB ASSY	Ref. pages 13 & 17
2-40	T601△*9125083000	POWER TRANS. (A-X1000) [US,C]	
	T601△*9125083200	POWER TRANS. (A-X1000) [E-D/DF]	
	T601△*9125083300	POWER TRANS. (A-X1000) [GE]	
	T601△*9125083700	POWER TRANS. (A-X1000) [UK,A]	
	T601△*9125083900	POWER TRANS. (A-X1000) [E,E-F]	
	T601△*9125084000	POWER TRANS. (A-X3000) [US,C]	
	T601△*9125084200	POWER TRANS. (A-X3000) [E-D/DF]	
	T601△*9125084300	POWER TRANS. (A-X3000) [GE]	
	T601△*9125084700	POWER TRANS. (A-X3000) [UK,A]	
	T601△*9125084900	POWER TRANS. (A-X3000) [E,E-F]	
2-41	△*5350010700	AC CORD UL SPT-2 [US,C,GE]	
	△*9109025701	AC CORD [E-D/F/DE,E]	
	△*9109025901	AC CARD [UK]	
	△*9109026000	AC CORD [A]	
2-42	*9121000101	BUSHING, #2271	
2-43	J101 *9143289000	GND TERMINAL, YKD41-0004	
2-44	S602△*5300918600	VOLTAGE SELECTOR,SDKGA4 [GE]	
2-45	*9260134300	PUSH BUTTON B(A-X3000 only)	
2-46	*5143248000	MOUNTING PLATE (A)	
2-47	*9260167900	VR.,COLLAR [GE,E only] A-X1000 : #030580 and before A-X3000 : #010510 and before	
2-51	*9783203008	SCREW, BTT-S M3X8	
2-52	*9783233008	SCREW, BTT-S M3X8 (BLK)	
2-53	*9783213012	SCREW, BTT-B M3X12	
2-54	*9783053006	SCREW, CAP-S M3X6 (BLK)	
2-55	*9783593008	SCREW,C-TITE M3X8(NI-BLK)	
2-56	*9783103006	SCREW, CAP-S M3X6	
2-57	*9783613008	SCREW, BTT-P M3X8 (BLK)	
2-58	*9783213008	SCREW, BTT-B M3X8	
2-59	*9783603008	SCREW, BTT-P M3X8	
2-60	*9783295010	SCREW, BTB-S M5X10	
2-61	*9783233008	SCREW, BTT-S M3X8 (BLK)	

[US]:U.S.A. [C]:CANADA [E-D]:GERM,SWEDEN,NORWAY,DENMARK [GE]:GENERAL EXPORT [UK]:U.K. [A]:AUSTRALIA [E]:SWITZLD,NETHLDS,GREECE,AUSTRIA,SPAIN,ITALY,TURKEY [E-F]:FRANCE,BELGIUM [E-DF]:FINLAND

Parts marked with *require longer delivery time.

5. PC BOARDS AND PARTS LIST

MAIN PCB ASSY

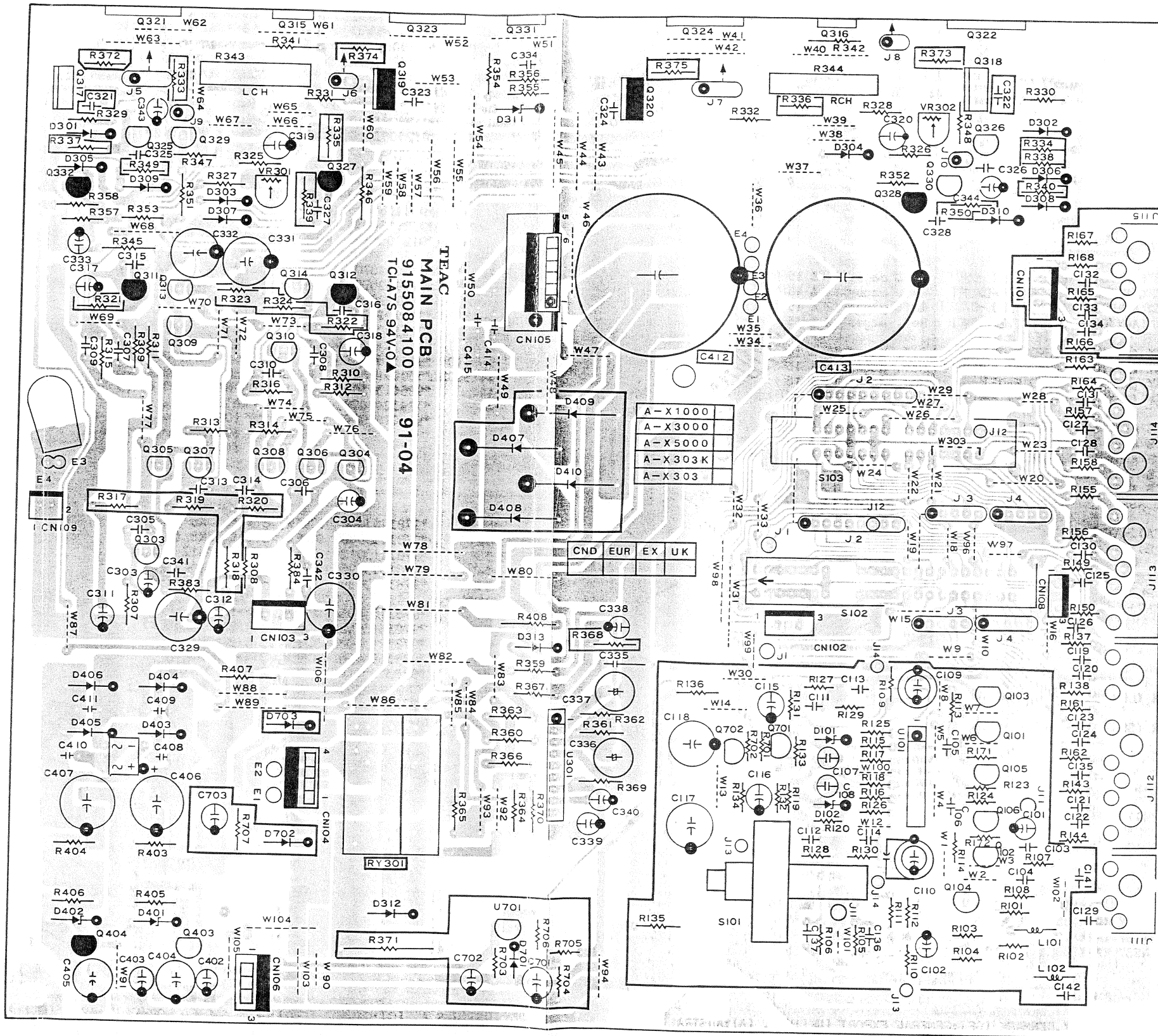

FRONT PCB ASSY

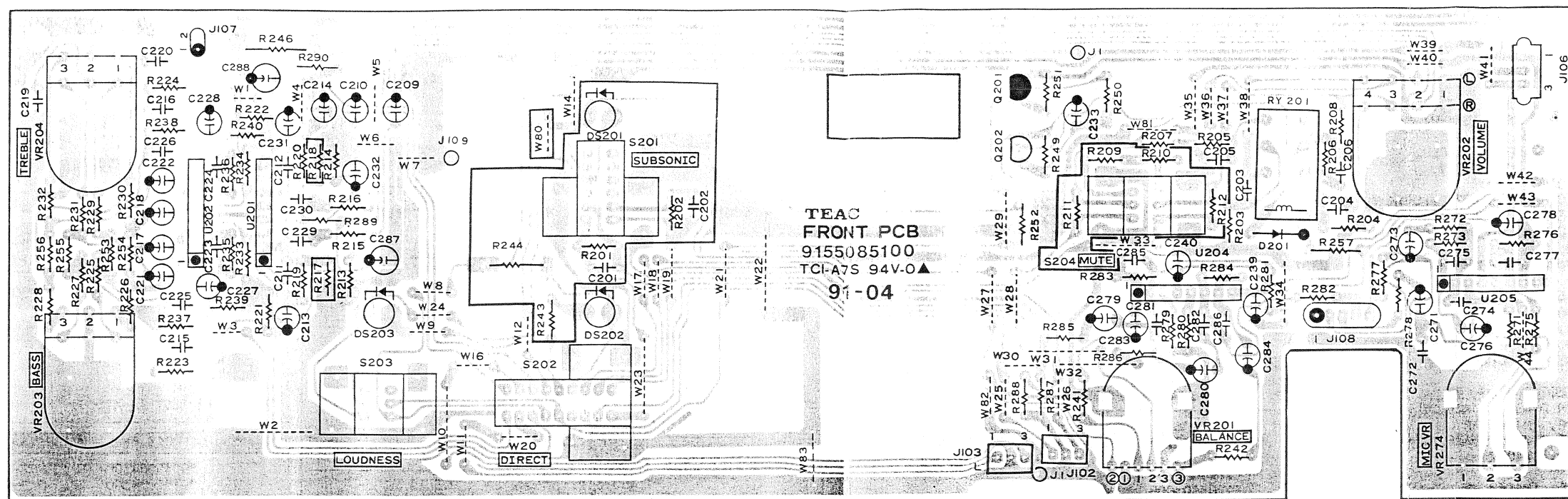

POWER SW PCB ASSY

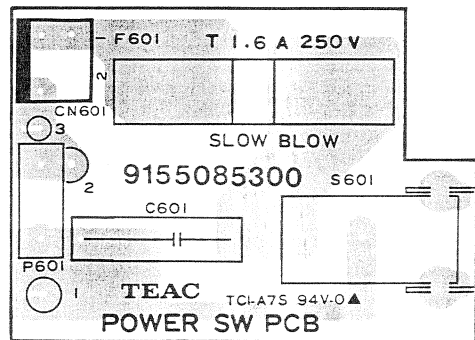

PHONE JACK PCB ASSY

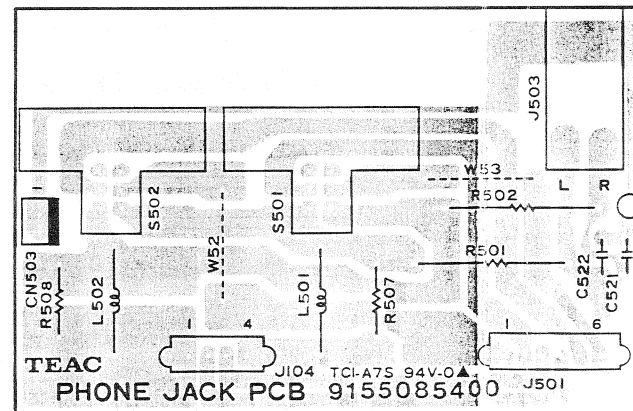

SPEAKER T.M PCB ASSY

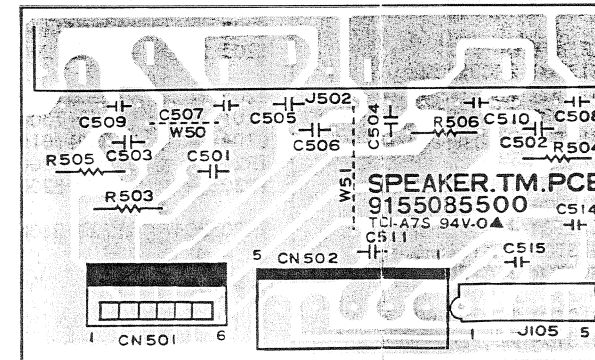

POWER LED PCB ASSY

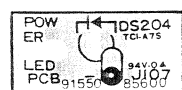

MIC. J PCB ASSY (A-X3000/A-X1000 only)

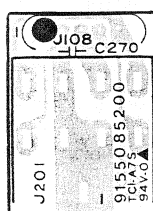

TR., PCB-1 ASSY (A-X5000 only)

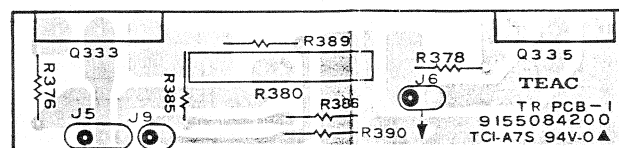

TR., PCB-2 ASSY (A-X5000 only)

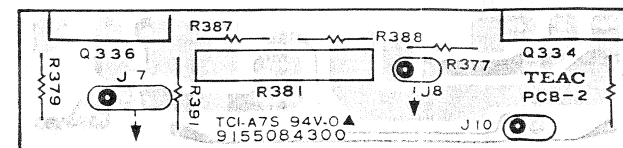

ELECTRICAL LIST

MAIN PCB ASSY (A-X5000)

REF.NO.	PARTS NO.	DESCRIPTION
	*9145084141	MAIN PCB ASSY [E-D,E-DF]
	*9145084151	MAIN PCB ASSY [EXCEPT E-D/DF]
	*9155084100	MAIN PCB
	*9229021000	EARTH PLATE (A) P.C.B.
C406 407	△9117259100	C., ELEC 1000UF/25V
C408-411	△9115819320	C., CERAMIC 0.022UF/100VK YB
C412 413	△9117302600	C., ELEC 12000UF/63V
C414 415	△9115818900	C., CERAMIC 0.01UF/500VK YB
CN101	9143171000	CONN.PLUG 3P
CN102	9143171020	CONN.PLUG 3P (B3B-EH-A)RED
CN103	9143171000	CONNECTOR PLUG, 3P
CN104	9143252000	CONNECTOR PLUG, 4P
CN105	9143254000	CONN.PLUG 6P [E-D,E-DF]
	9143301000	CONN.PLUG 5P [EXCEPT E-D/DF]
CN106	9143251000	CONNECTOR PLUG, 3P
CN109	9143170000	CONNECTOR PLUG, 2P
D101 102	9166032201	ZENER DIODE, 05AZ6.2Y
D301-310	△9165020850	DIODE, IN4148 TP
D311	9166032201	ZENER DIODE, 05AZ6.2Y
D312	9165021900	DIODE, IN4002
D313	9165020850	DIODE, IN4148 TP
D401 402	9166033201	ZENER DIODE, 05AZ16Y
D403-406	△9165021900	DIODE, IN4002
D407-410	△9165022300	DIODE, PR6003
D701 703	9165021900	DIODE, IN4002
J111	9143310000	PIN JACK, 2P (YKC21-2431)
J112	9143306000	PIN JACK, 6P (YKC21-2229)
J113-115	9143305000	PIN JACK, 4P (YKC21-2226)
L101 102	9173006320	COIL, 220UH [E-D,E-DF]
Q101-104	9163312320	TRANSISTOR 2SC3329GR
Q105 106	5232008400	FET., 2SK381D
Q303-310	9163311520	TRANSISTOR 2SC2240GR
Q311 312	9163012200	TRANSISTOR 2SA1145-0
Q313 314	9163311600	TRANSISTOR 2SC2705-0
Q315 316	5230782900	TRANSISTOR 2SC1846 R
Q317 318	9163311400	TRANSISTOR 2SC3298-Y
Q319 320	9163012100	TRANSISTOR 2SA1306-Y
Q321 322	9163312200	TRANSISTOR 2SC3907-0
Q323 324	9163012700	TRANSISTOR 2SA1516-0
Q325 326	9163309420	TRANSISTOR 2SC1815GR
Q327 328	9163009920	TRANSISTOR 2SA1015GR
Q329 330	9163311520	TRANSISTOR 2SC2240GR
Q331	5230782900	TRANSISTOR 2SC1846 R
Q332	9163011720	TRANSISTOR 2SA970-BL
Q403	△9163308900	TRANSISTOR 2SC2235Y
Q404	△9163009400	TRANSISTOR 2SA-965Y
Q701 702	9163310620	TRANSISTOR 2SC2878A
R135 136	△9111810000	R., NONFLAMMABLE 1/4W 100
R321 322	9114100810	R., NONFLAMMABLE 1W 68
R329-332	△9114100910	R., NONFLAMMABLE 1/2W 22
R341 342	△9114258060	R., NONFLAMMABLE 1/2W 220
R343 344	△5241503100	R., CEMENT 0.22+0.22OHM 5W
R345 346	△9114101010	R., NONFLAMMABLE 1W 100
R371	△9111238000	R., CARBON 2W 1K
R403 404	△9114033060	R., NONFLAMMABLE 1/4W 22

MAIN PCB ASSY (A-X5000)

REF.NO.	PARTS NO.	DESCRIPTION
R407 408	△9114209060	R.,NONFLAMMABLE 1/2W 2.2
RY301	5290015000	RELAY DE24D2-0T(M)
S101	9135031600	PUSH SW, 2-2 SPX-04
S102	5300918400	SW.,SLIDE SSSR26
S103	5300918500	SW.,SLIDE SSSR24
S102	5301207000	ROTARY FLEX (B) SRBU06
S103	5301206900	ROTARY FLEX SRBU06
U101	9167015010	IC, M5218L
U301	9167008200	IC, TA7317P
U701	9163011420	TRANSISTOR DTA114ES TP.
VR301302	9112058000	SEMI-FIXED VR 1K (B)

FRONT PCB ASSY (A-X5000)

REF.NO.	PARTS NO.	DESCRIPTION
	*9145086101	FRONT PCB ASSY [E-D,E-DF]
	*9145086111	FRONT PCB ASSY [EXCEPT E-D/DF]
	*9155086100	FRONT PCB
	*9783603008	SCREW, BTT-P M3X8
D201	9165021900	DIODE, IN4002
DS201-203	9174012320	LED,5-333FY/HO YEL
DS205	9174012320	LED,5-333FY/HO YEL
J106	9143261100	WIRE HOLDER, 3P SC-003
Q201	9163009920	TRANSISTOR 2SA1015GR
Q202	9163309420	TRANSISTOR 2SC1815GR
RY201	5290015100	RELAY SVR24A
S201	9135031300	PUSH SW 4-2 SPEC12HA02-TK
S202	9135031400	PUSH SW 6-2 SPEC12HA04-TK
S203 204	9135031200	PUSH SW 2-2 SPEC12HA01-TK
S205	9135031300	PUSH SW 4-2 SPEC12HA02-TK
U201 202	9167017300	IC, NJM 4565LD
U204	9167015010	IC, M5218L
VR201	9172018000	BALANCE VR 150KMN
VR202	9172018200	VOLUME VR 100KBX2
VR203204	9172018100	TONE VR, 20KBX2

POWER SW PCB ASSY (A-X5000)

REF.NO.	PARTS NO.	DESCRIPTION
	*9145086200	POWER SW PCB ASSY [E,E-D/F/DF]
	*9145086210	POWER SW PCB ASSY [US,C,GE]
	*9145086220	POWER SW PCB ASSY [UK,A]
	*9155086200	POWER SW PCB
	*9150013000	FUSE HOLDER, S-N5051 [US,C,GE]
	*9150014000	FUSE HOLDER, S-N5053 [EXCEPT US,C,GE]
C601	△5267704000	SPARK,KILLER 0.0047UF250V
CN601	9143311000	CONNECTOR PLUG2P (5289-2A)
F601	△5142191000	FUSE,3.15A-250V T,MINI [EXCEPT US,C,GE]
F601	△9150017000	FUSE, 6A 250V SLOW [US,C,GE]
P601	5327009600	TERMINAL LAPPING 2P
S601	△9135031500	POWER SW

PHONE JACK PCB ASSY (A-X5000)

REF.NO.	PARTS NO.	DESCRIPTION
	*9145086301	PHONE JACK PCB ASSY [E-D,E-DF]
	*9145086311	PHONE JACK PCB ASSY [EXCEPT E-D,E-DF]
	*9155086300	PHONE JACK PCB
	*9290000400	MOUNTING PLATE (A)
CN503	9143170000	CONNECTOR PLUG, 2P
J104	9143262100	WIRE HOLDER, 4P SC-004
J501	9143264100	WIRE HOLDER, 6P SC-006
J503	9143248000	PHONE JACK (YKB21-5138A)
R501 502	△9111232000	R., CARBON 2W 430
S501 502	9135029000	POWER SW (R-3271)

SPEAKER TM PCB ASSY (A-X5000)

REF.NO.	PARTS NO.	DESCRIPTION
	*9145086401	SPEAKER TM PCB ASSY [E-D/DF]
	*9145086411	SPEAKER TM PCB ASSY [US,C,GE,A,E, E-F]
	*9145086420	SPEAKER TM PCB ASSY [UK]
	*9155086400	SPEAKER TM PCB
C514 515	△9115818900	C. CERA 0.01UF/500VK [E-D/DF]
CN501	9143254000	CONN. PLUG 6P (52011-0610)
CN502	9143301000	CONN. PLUG 5P [E-D,E-DF]
J105	9143264100	WIRE HOLDER, 6P SC-006 [E-D/DF]
J502	9143302000	SP.TERM.8P YKD310372 [EXCEPT UK]
	9143303000	SP.TERM.8P YKD310402 [UK]
R503-506	9114033060	R.,NONFLAMMABLE 1/4W 22 OHM [E-D/DF]

[US]:U.S.A. [C]:CANADA [E-D]:GERM,SWEDEN,NORWAY,DENMARK [GE]:GENERAL EXPORT [UK]:U.K. [A]:AUSTRALIA [E]:SWITZLD,NETHLD,GREECE,AUSTRIA,SPAIN,ITALY,TURKEY [E-F]:FRANCE,BELGIUM [E-DF]:FINLAND

Parts marked with *require longer delivery time.

POWER LED PCB ASSY (A-X5000)

REF.NO.	PARTS NO.	DESCRIPTION
	*9145086500	POWER LED PCB ASSY
	*9155086500	POWER LED PCB
DS204	9174012320	LED,5-333FY/HO YEL
TR., PCB-1 ASSY (A-X5000)		
	*9145084200	TR., PCB-1 ASSY
	*9155084200	TR., PCB-1
Q333	9163312200	TRANSISTOR 2SC3907-0
Q335	9163012700	TRANSISTOR 2SA1516-0
R376 378	9111010050	R., CARBON R-25 JFT 5.6
R380	△5241503100	R., CEMENT 0.22+0.22 OHM 5W
TR., PCB-2 ASSY (A-X5000)		
	*9145084300	TR., PCB-2 ASSY
	*9155084300	TR., PCB-2
Q334	9163312200	TRANSISTOR 2SC3907-0
Q336	9163012700	TRANSISTOR 2SA1516-0
R381	△5241503100	R., CEMENT 0.22+0.22 OHM 5W

[US]:U.S.A. [C]:CANADA [E-D]:GERM,SWEDEN,NORWAY,DENMARK [GE]:GENERAL EXPORT [UK]:U.K. [A]:AUSTRALIA [E]:SWITZLD,NETHLD,GREECE,AUSTRIA,SPAIN,ITALY,TURKEY [E-F]:FRANCE,BELGIUM [E-DF]:FINLAND

Parts marked with *require longer delivery time.

MAIN PCB ASSY (A-X3000)

REF.NO.	PARTS NO.	DESCRIPTION
	*9145084120	MAIN PCB ASSY [E-D,E-DF]
	*9145084130	MAIN PCB ASSY [EXCEPT E-D/DF]
	*9155084100	MAIN PCB
	*9229021000	EARTH PLATE (A) P.C.B.
	*9783213008	SCREW, BTT-B M3X8
	*9783613008	SCREW, BTT-P M3X8 (BLK)
	*9783103006	SCREW, CAP-S M3X6
C105 106	9115800020	C., CERAMIC 1000PF/50VK YB
C406 407	△ 9117259100	C., ELEC 1000UF/25V
C408-411	△ 9115819320	C. CERAMIC 0.022UF/100VK YB
C412 413	△ 9117278100	C., ELEC 10000UF/63V
C414 415	△ 9115818900	C. CERAMIC 0.01UF/500VK YF
CN102	9143171020	CONN. PLUG 3P (B3B-EH-A) RED
CN103	9143171000	CONNECTOR PLUG, 3P
CN104	9143252000	CONNECTOR PLUG, 4P
CN105	9143254000	CONN. PLUG 6P [E-D,E-DF]
	9143301000	CONN. PLUG 5P [EXCEPT E-D/DF]
CN106	9143251000	CONNECTOR PLUG, 3P
CN109	9143170000	CONNECTOR PLUG, 2P
D301-310	△ 9165020850	DIODE, IN4148 TP
D311	9166032201	ZENER DIODE, 05AZ6.2Y
D312	9165021900	DIODE, IN4002
D313	9165020850	DIODE, IN4148 TP
D401 402	9166033201	ZENER DIODE, 05AZ16Y
D403-406	△ 9165021900	DIODE, IN4002
D407-410	△ 9165022300	DIODE, PR6003
J111	9143304000	PIN JACK, 2P (YKC21-2430)
J112	9143306000	PIN JACK, 6P (YKC21-2229)
J113 114	9143305000	PIN JACK, 4P (YKC21-2226)
Q303-310	9163311520	TRANSISTOR 2SC2240GR
Q311 312	9163012200	TRANSISTOR 2SA1145-0
Q313 314	9163311600	TRANSISTOR 2SC2705-0
Q315 316	5230782900	TRANSISTOR 2SC1846 R
Q317 318	9163311400	TRANSISTOR 2SC3298-Y
Q319 320	9163012100	TRANSISTOR 2SA1306-Y
Q321 322	9163311700	TRANSISTOR 2SC3281-0
Q323 324	9163012300	TRANSISTOR 2SA1302-0
Q325 326	9163309420	TRANSISTOR 2SC1815GR
Q327 328	9163009920	TRANSISTOR 2SA1015GR
Q329 330	9163311520	TRANSISTOR 2SC2240GR
Q331	5230782900	TRANSISTOR 2SC1846 R
Q332	9163011720	TRANSISTOR 2SA970-BL
Q403	△ 9163308900	TRANSISTOR 2SC2235Y
Q404	△ 9163009400	TRANSISTOR 2SA-965Y
R135 136	△ 9111810000	R., NONFLAMMABLE 1/4W 100
R321 322	9114100710	R., NONFLAMMABLE 1W 62
R323 324	9111046050	R., CARBON R-25 JFT 150
R329-332	△ 9114033000	R., NONFLAMMABLE 1/4W 22
R341 342	△ 9114258000	R., NONFLAMMABLE 1/2W 220
R343 344	△ 5241503100	R., CEMENT 0.22+0.22 OHM 5W
R345 346	△ 9114101010	R., NONFLAMMABLE 1W 100
R371	△ 9111233000	R., CARBON 2W 820
R403 404	△ 9114033000	R., NONFLAMMABLE 1/4W 22
R407 408	△ 9114209000	R., NONFLAMMABLE 1/2W 2.2
RY301	5290014900	RELAY DH24D2-OS(M)

MAIN PCB ASSY (A-X3000)

REF.NO.	PARTS NO.	DESCRIPTION
S102	5300918400	SW., SLIDE SSSR26
S103	5300918500	SW., SLIDE SSSR24
S102 103	5301206900	ROTARY FREX SRBU06
U101	9167017300	IC, NJM 4565LD
U301	9167008200	IC, TA7317P
VR301302	9112058000	SEMI-FIXED VR 1K (B)

MAIN PCB ASSY (A-X1000)

REF.NO.	PARTS NO.	DESCRIPTION
	*9145084100	MAIN PCB ASSY [E-D,E-DF]
	*9145084110	MAIN PCB ASSY [EXCEPT E-D/DF]
	*9155084100	MAIN PCB
	*9229021000	EARTH PLATE (A) PCB
	*9783213008	SCREW, BTT-B M3X8
	*9783613008	SCREW, BTT-P M3X8 (BLK)
	*9783103006	SCREW, CAP-S M3X6
C105 106	9115800020	C., CERAMIC 1000PF/50VK YB
C406 407	9117259100	C., ELEC 1000UF/25V
C408-411	9115819320	C., CERAMIC 0.022UF/100VK
C412 413	9117302300	C., ELEC 6800UF/50V
C414 415	9115818900	C., CERAMIC 0.01UF/500VK
CN102	9143171020	CONN. PLUG 3P (B3B-EH-A) RED
CN103	9143171000	CONNECTOR PLUG, 3P
CN104	9143252000	CONNECTOR PLUG, 4P
CN105	9143254000	CONN. PLUG 6P [E-D,E-DF]
CN106	9143301000	CONN. PLUG 5P [EXCEPT E-D/DF]
CN109	9143251000	CONNECTOR PLUG, 3P
	9143170000	CONNECTOR PLUG, 2P
D301-310	9165020850	DIODE, IN4148 TP
D311	9166032201	ZENER DIODE, 05AZ6.2Y
D312	9165021900	DIODE, IN4002
D313	9165020850	DIODE, IN4148 TP
D401 402	9166033201	ZENER DIODE, 05AZ16Y
D403-406	9165021900	DIODE, IN4002
D407-410	9165022200	DIODE, PR3003
J111	9143304000	PIN JACK, 2P (YKC21-2430)
J112	9143306000	PIN JACK, 6P (YKC21-2229)
J113 114	9143305000	PIN JACK, 4P (YKC21-2226)
Q303-310	9163311520	TRANSISTOR 2SC2240GR
Q311 312	9163012200	TRANSISTOR 2SA1145-0
Q313 314	9163311600	TRANSISTOR 2SC2705-0
Q315 316	5230782900	TRANSISTOR 2SC1846 R
Q317 318	9163311400	TRANSISTOR 2SC3298-Y
Q319 320	9163012100	TRANSISTOR 2SA1306-Y
Q321 322	9163311800	TRANSISTOR 2SC3181-0
Q323 324	9163012400	TRANSISTOR 2SA1264-0
Q325 326	9163309420	TRANSISTOR 2SC1815GR
Q327 328	9163009920	TRANSISTOR 2SA1015GR
Q329 330	9163311520	TRANSISTOR 2SC2240GR

[US]:U.S.A. [C]:CANADA [E-D]:GERM, SWEDEN, NORWAY, DENMARK [GE]:GENERAL EXPORT [UK]:U.K. [A]:AUSTRALIA [E]:SWITZLD, NETHLDS, GREECE, AUSTRIA, SPAIN, ITALY, TURKEY [E-F]:FRANCE, BELGIUM [E-DF]:FINLAND

Parts marked with *require longer delivery time.

MAIN PCB ASSY (A-X1000)

REF.NO.	PARTS NO.	DESCRIPTION
Q331	5230782900	TRANSISTOR 2SC1846 R
Q332	9163011720	TRANSISTOR 2SA970-BL
Q403	9163308900	TRANSISTOR 2SC2235Y
Q404	9163009400	TRANSISTOR 2SA-965Y
R135 136	9111810000	R., NONFLAMMABLE 1/4W 100
R329-332	9114033000	R., NONFLAMMABLE 1/4W 22
R341 342	9114258000	R., NONFLAMMABLE 1/2W 220
R343 344	5241503100	R., CEMENT 0.22+0.22 OHM 5W
R345 346	9114250000	R., NONFLAMMABLE 1/2W 100
R371	9111236000	R., CARBON 2W 560
R403 404	9114033000	R., NONFLAMMABLE 1/4W 22
R407 408	9114209000	R., NONFLAMMABLE 1/2W 2.2
RY301	5290014900	RELAY DH24D2-OS(M)
S102	5300918400	SW., SLIDE SSSR26
S103	5300918500	SW., SLIDE SSSR24
S102 103	5301206900	ROYARY FLEX SRBU06
U101	9167017300	IC, NJM 4565LD
U301	9167008200	IC, TA7317P
VR301302	9112058000	SEMI-FIXED VR 1K (B)

FRONT PCB ASSY (A-X3000)

REF.NO.	PARTS NO.	DESCRIPTION
	*9145085121	FRONT PCB ASSY [E-D,E-DF]
	*9145085131	FRONT PCB ASSY [EXCEPT E-D/DF]
	*9155085100	FRONT PCB
D201-203	*9783603008	SCREW, BTT-P M3X8
	9165021900	DIODE, IN4002
DS201-203	9174012320	LED,5-333FY/HO YEL
J106	9143261100	WIRE HOLDER, 3P SC-003
Q201	9163009920	TRANSISTOR 2SA1015GR
Q202	9163309420	TRANSISTOR 2SC1815GR
RY201	5290015100	RELAY SVR24A
S201	9135031300	PUSH SW 4-2 SPEC12HA02-TK
S202	9135031400	PUSH SW 6-2 SPEC12HA04-TK
S203 204	9135031200	PUSH SW 2-2 SPEC12HA01-TK
U201 202	9167017300	IC, NJM 4565LD
U204	9167015010	IC, M5218L
U205	9167017300	IC, NJM 4565LD
VR201	9172018000	BALANCE VR 150KMN
VR202	9172018200	VOLUME VR 100KBX2
VR203204	9172018101	TONE VR 20KBX2
VR274	9172017900	MIC VR RK16K1140034-TK10K

FRONT PCB ASSY (A-X1000)

REF.NO.	PARTS NO.	DESCRIPTION
	*9145085101	FRONT PCB ASSY [E-D,E-DF]
	*9145085111	FRONT PCB ASSY [EXCEPT E-D/DF]
	*9155085100	FRONT PCB
D201-203	*9783603008	SCREW, BTT-P M3X8
	9165021900	DIODE, IN4002

FRONT PCB ASSY (A-X1000)

REF.NO.	PARTS NO.	DESCRIPTION
DS202203	9174012320	LED,5-333FY/HO YEL
J106	9143261100	WIRE HOLDER, 3P SC-003
Q201	9163009920	TRANSISTOR 2SA1015GR
Q202	9163309420	TRANSISTOR 2SC1815GR
RY201	5290015100	RELAY SVR24A
S202	9135031400	PUSH SW 6-2 SPEC12HA04-TK
S203	9135031200	PUSH SW 2-2 SPEC12HA01-TK
U201 202	9167017300	IC, NJM 4565LD
U204	9167015010	IC, M5218L
U205	9167017300	IC, NJM 4565LD
VR201	9172018000	BALANCE VR 150KMN
VR202	9172018200	VOLUME VR 100KBX2
VR203204	9172018101	TONE VR 20KBX2
VR274	9172017900	MIC VR RK16K1140034-TK10K

POWER SW PCB ASSY (A-X3000)

REF.NO.	PARTS NO.	DESCRIPTION
	*9145085340	POWER SW PCB ASSY [US,C]
	*9145085350	POWER SW PCB ASSY [E,E-D/F/DF]
	*9145085360	POWER SW PCB ASSY [GE]
	*9145085370	POWER SW PCB ASSY [UK,A]
	*9155085300	POWER SW PCB
	*9150013000	FUSE HOLDER, S-N5051 [US,C,GE]
	*9150018000	FUSE HOLDER, 2-N1152 [EXCEPT US,C,GE]
C601	*9783603008	SCREW, BTT-P M3X8
	Δ 5267704000	SPARK,KILLER 0.0047UF250V
CN601	9143311000	CONNECTOR PLUG2P (5289-2A)
F601	Δ 5142190000	FUSE,2.5A-250V(T) [EXCEPT US,C,GE]
	Δ 9150016000	FUSE,5A0250V SLOW [US,C,GE]
P601	5327009600	TERMINAL LAPPING 2P [E-D/F/DF,E]
S601	Δ 9135031500	POWER SW

POWER SW PCB ASSY (A-X1000)

REF.NO.	PARTS NO.	DESCRIPTION
	*9145085300	POWER SW PCB ASSY [US,C]
	*9145085310	POWER SW PCB ASSY [E-D/F/DF,E]
	*9145085320	POWER SW PCB ASSY [GE]
	*9145085330	POWER SW PCB ASSY [UK,A]
	*9155085300	POWER SW PCB
	*9150013000	FUSE HOLDER,S-N5051 [US,C,GE]
	*9150018000	FUSE HOLDER,2-N1152 [EXCEPT US,C,GE]
C601	*9783603008	SCREW, BTT-P M3X8
	Δ 5267704000	SPARK,KILLER 0.0047UF250V
CN601	9143311000	CONNECTOR PLUG 2P (5289-2A)
F601	Δ 5142188000	FUSE,1.6A-250V(T) [EXCEPT US,C,GE]
	Δ 9150015000	FUSE,4A 250V SLOW [US,C,GE]
P601	5327009600	TERMINAL LAPPING 2P [E-D/F/DF,E]
S601	Δ 9135031500	POWER SW

[US]:U.S.A. [C]:CANADA [E-D]:GERM,SWEDEN,NORWAY,DENMARK [GE]:GENERAL EXPORT [UK]:U.K. [A]:AUSTRALIA [E]:SWITZLD,NETHLD,GREECE,AUSTRIA,SPAIN,ITALY,TURKEY [E-F]:FRANCE,BELGIUM [E-DF]:FINLAND

Parts marked with *require longer delivery time.

PHONE JACK PCB ASSY

REF.NO.	PARTS NO.	DESCRIPTION
	*9145085401	PHONE JACK PCB ASSY [E-D/DF]
	*9145085411	PHONE JACK PCB ASSY [EXCEPT E-D/DF]
	*9155085400	PHONE JACK PCB
	*9290000400	MOUNTING PLATE (A)
	*9783603008	SCREW, BTT-P M3X8
CN503	9143170000	CONNECTOR PLUG, 2P
J104	9143262100	WIRE HOLDER, 4P SC-004
J501	9143264100	WIRE HOLDER, 6P SC-006
J503	9143248000	PHONE JACK (YKB21-5138A)
R501 502 Δ	9111232000	R., CARBON 2W 430
S501 502	9135029000	POWER SW (R-3271)

SPEAKER TM.PCB ASSY

REF.NO.	PARTS NO.	DESCRIPTION
	*9145085501	SPK.TM.PCB ASSY [E-D,E-DF]
	*9145085511	SPK.TM.PCB ASSY [US,C,GE,A,E,E-F]
	*9145085521	SPK.TM.PCB ASSY [UK]
	*9155085500	SPEAKER TM.PCB
	*9783613008	SCREW, BTT-P M3X8 (BLK)
C514 515 Δ	9115818900	C.CERAMIC 0.01UF/500VK YF
CN501	9143254000	CONNEC.PLUG6P (52011-0610)
CN502	9143301000	CONNECTO.PLUG5P (5281-05A)
J105	9143264100	WIRE HOLDER, 6P SC-006
J502	9143302000	SP.TERM.8P YKD310372 [UK]
	9143303000	SP.TERM.8P YKD310402 [EXCEPT UK]
R503-506	9114033000	R., NONFLAMMABLE 1/4W 22OHM [E-D,E-DF]

MIC. J PCB ASSY

REF.NO.	PARTS NO.	DESCRIPTION
	*9145085200	MIC. J PCB ASSY
	*9155085200	MIC. J PCB
	*9290000400	MOUNTING PLATE (A)
J201	9143281000	MIC JACK (YKB21-5008)

POWER LED PCB ASSY

REF.NO.	PARTS NO.	DESCRIPTION
	*9145085600	POWER LED PCB ASSY
	*9155085600	POWER LED PCB
DS204	9174012320	LED,5-333FY/HO YEL

[US]:U.S.A. [C]:CANADA [E-D]:GERM,SWEDEN,NORWAY,DENMARK [GE]:GENERAL EXPORT [UK]:U.K. [A]:AUSTRALIA
[E]:SWITZLD,NETHLD,GREECE,AUSTRIA,SPAIN,ITALY,TURKEY [E-F]:FRANCE,BELGIUM [E-DF]:FINLAND

Parts marked with *require longer delivery time.

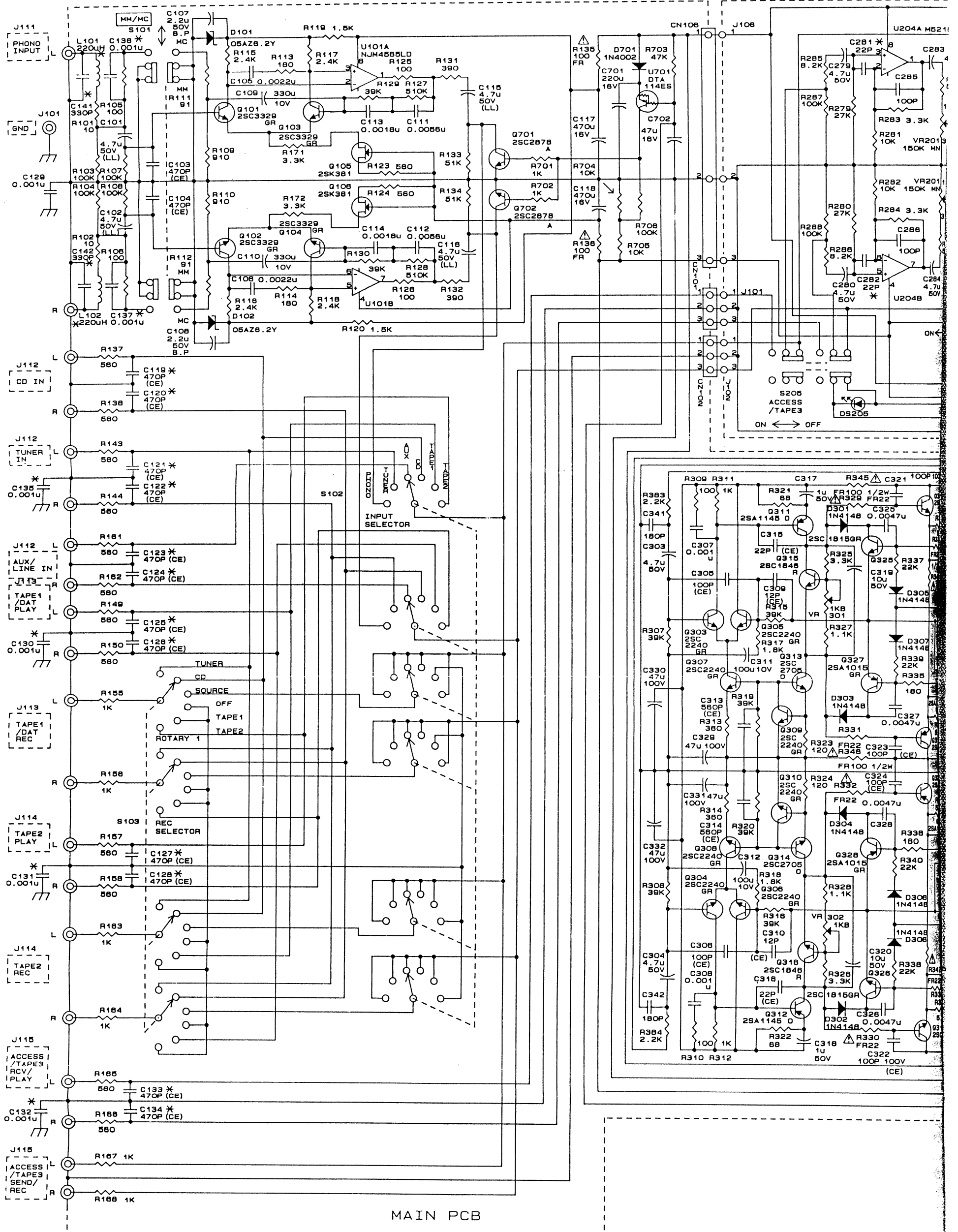

MAIN PCB

1A

INSTRUCTIONS FOR SERVICE PERSONAL
BEFORE RETURNING APPLIANCE TO THE CUSTOMER. MAKE LEAKAGE.

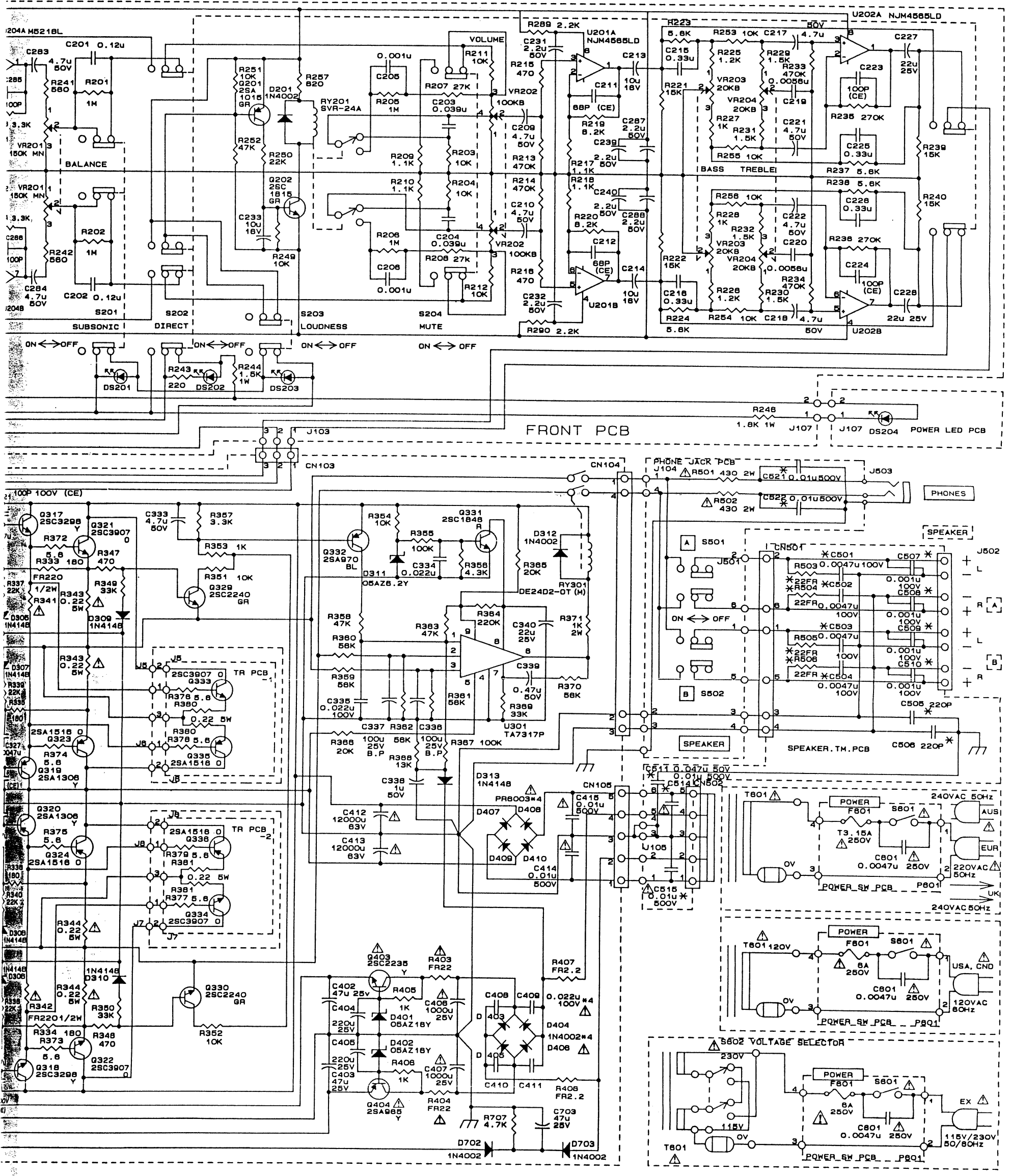

**** NOTE ****
 1. ALL RESISTORS ARE 1/8W CARBON FILM RESISTOR UNLESS OTHERWISE LISTED.
 RESISTANCE UNIT IS IN OHM, K=1,000, M=1,000,000
 1/2R = METAL OR METAL OXIDE 1/2W. 1/2S = SOLID 1/2W.
 1/2F = FUSE RESISTOR 1/2W. 10W = CEMENT RESISTOR 10W.
 2. ALL CAPACITORS ARE 50V CERAMIC CAPACITOR UNLESS OTHERWISE LISTED.
 CAPACITANCE LESS THAN 1 ARE EXPRESS IN UF. AND GREATER THAN 1 IN PF.
**** IMPORTANT SAFETY NOTICE ****
 COMPONENTS IDENTIFIED BY Δ MARK HAVE SPECIAL CHARACTERISTICS IMPORTANT FOR SAFETY.
 WHEN REPLACING ANY OF THESE COMPONENTS USE ONLY MANUFACTURER'S SPECIFIED PARTS.

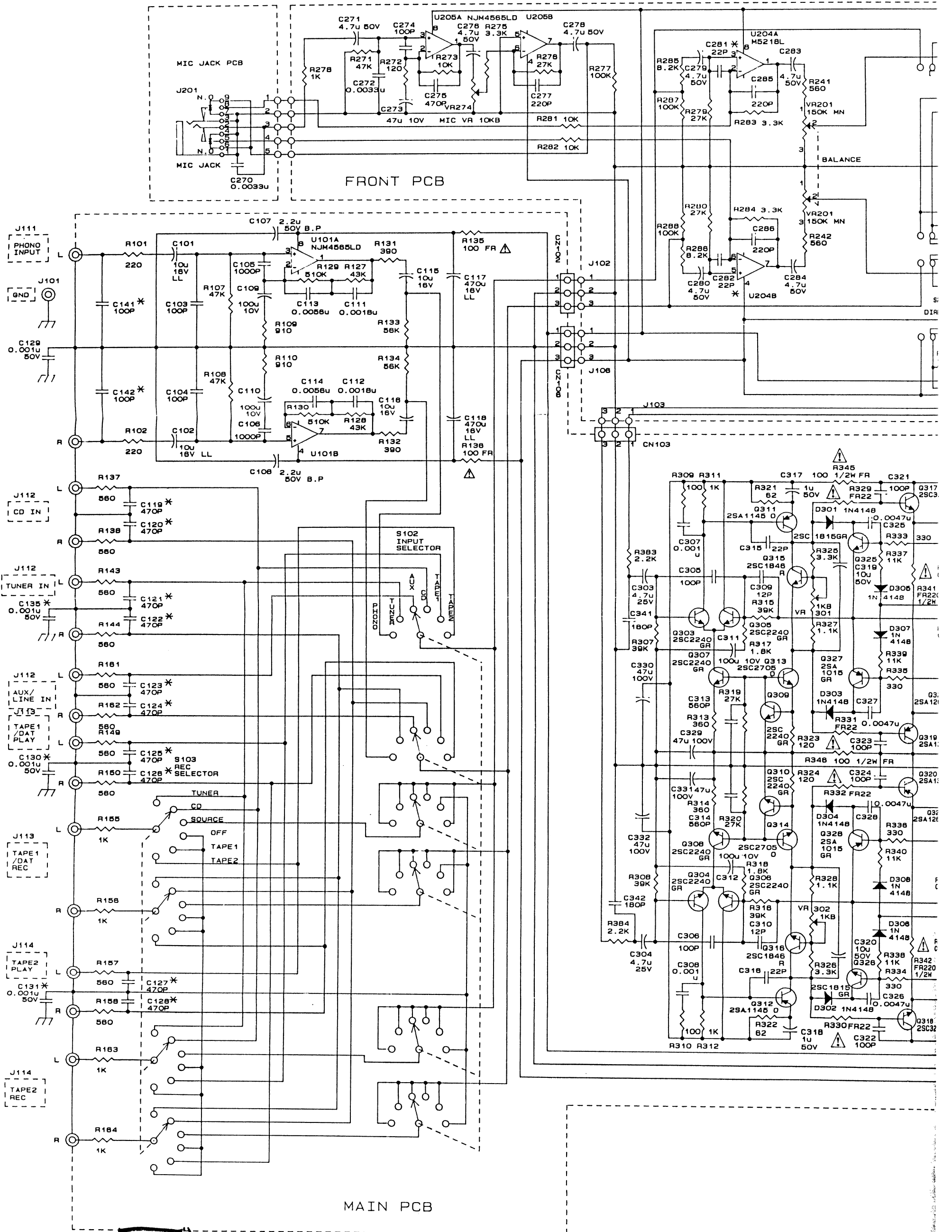

2A

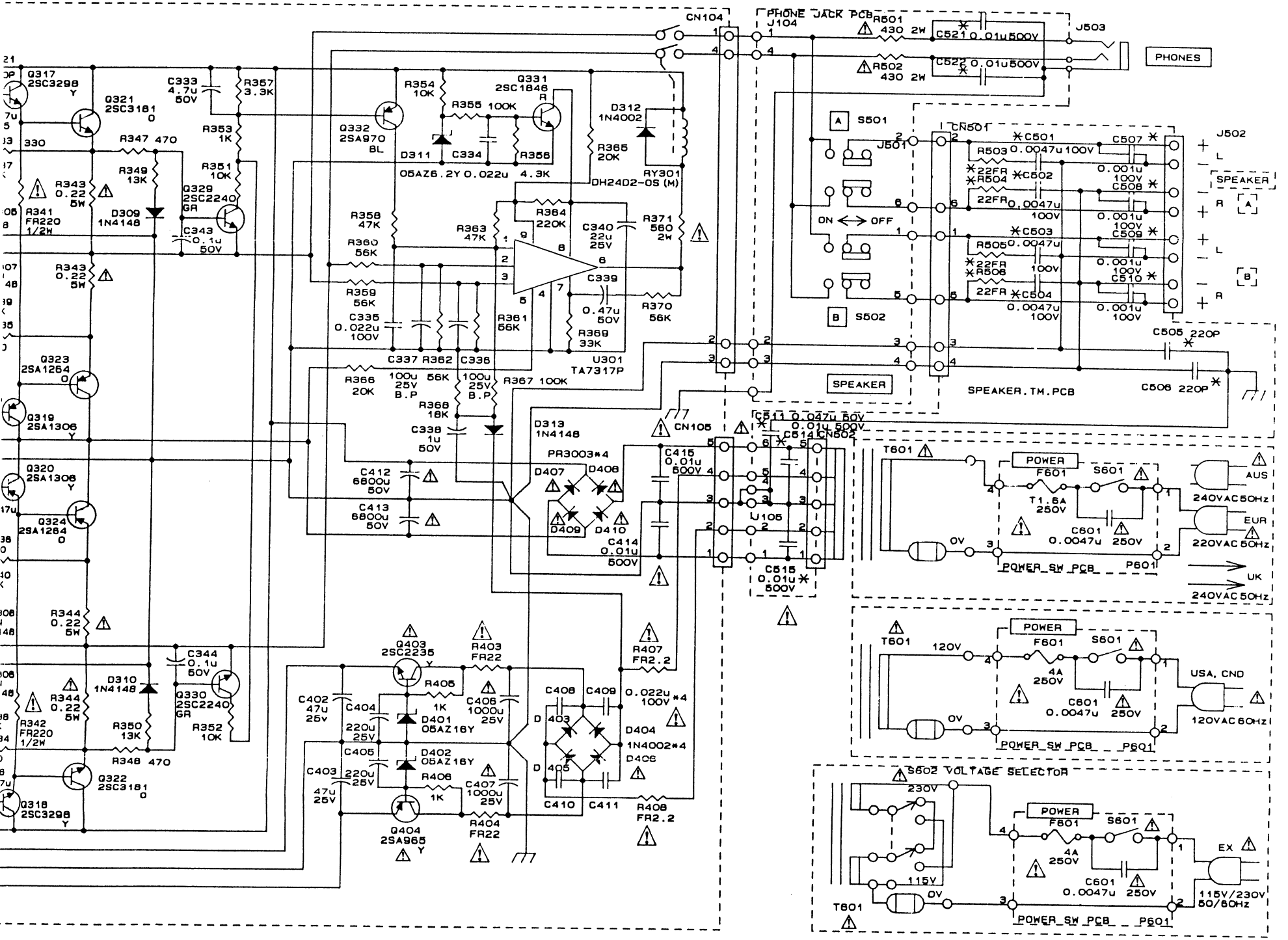
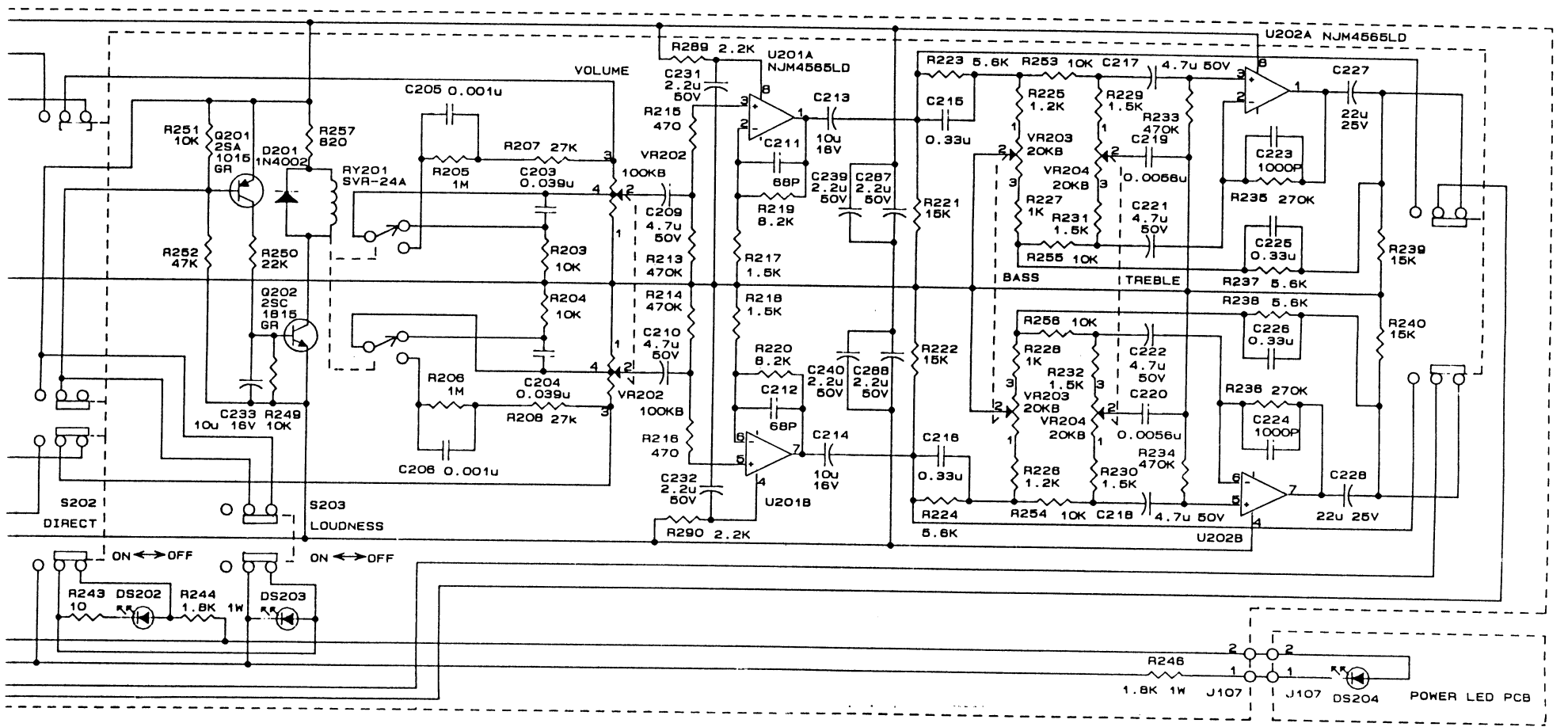

**** NOTE ****

1. ALL RESISTORS ARE 1/8W CARBON FILM RESISTOR UNLESS OTHERWISE LISTED.
RESISTANCE UNIT IS IN OHM. K=1,000 M=1,000,000
1/2W : METAL OXIDE METAL OXIDE 1/2W. 1/25 : SOLID 1/2W.

2. ALL CAPACITORS ARE 50V CERAMIC CAPACITOR UNLESS OTHERWISE LISTED.
CAPACITANCE LESS THAN 1 ARE EXPRESS IN nF. AND GREATER THAN 1 IN μF.

**** IMPORTANT SAFETY NOTICE ****

COMPONENTS IDENTIFIED BY ▲ MARK HAVE SPECIAL CHARACTERISTICS IMPORTANT FOR SAFETY.

WHEN REPLACING ANY OF THESE COMPONENTS USE ONLY MANUFACTURER'S SPECIFIED PARTS.

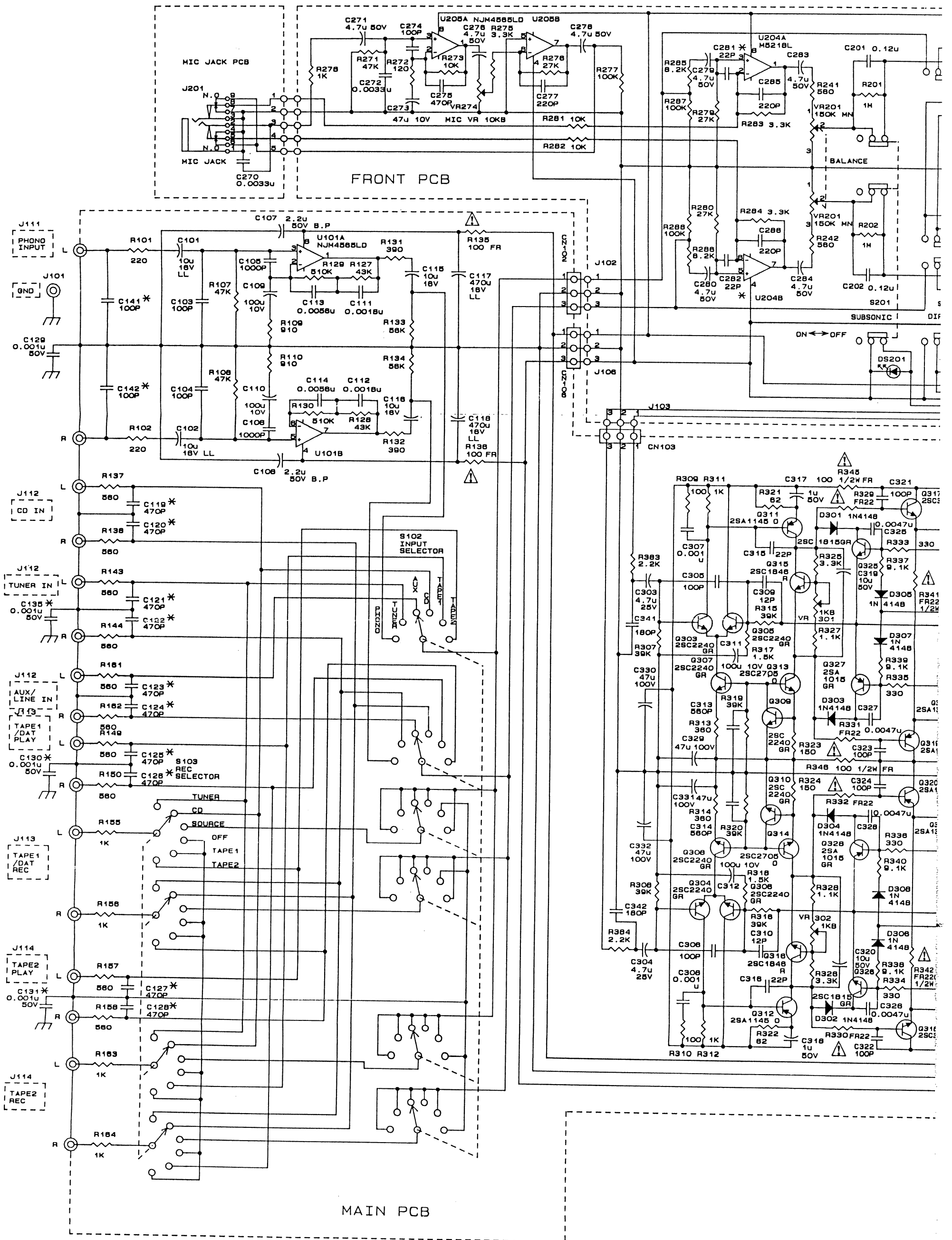

INSTRUCTIONS FOR SERVICE PERSONAL
 BEFORE RETURNING APPLIANCE TO THE CUSTOMER, MAKE LEAKAGE-CURRENT OR RESISTANCE MEASUREMENTS TO DETERMINE THAT EXPOSED PARTS ARE ACCEPTABLY INSULATED FROM EACH OTHER.

3A

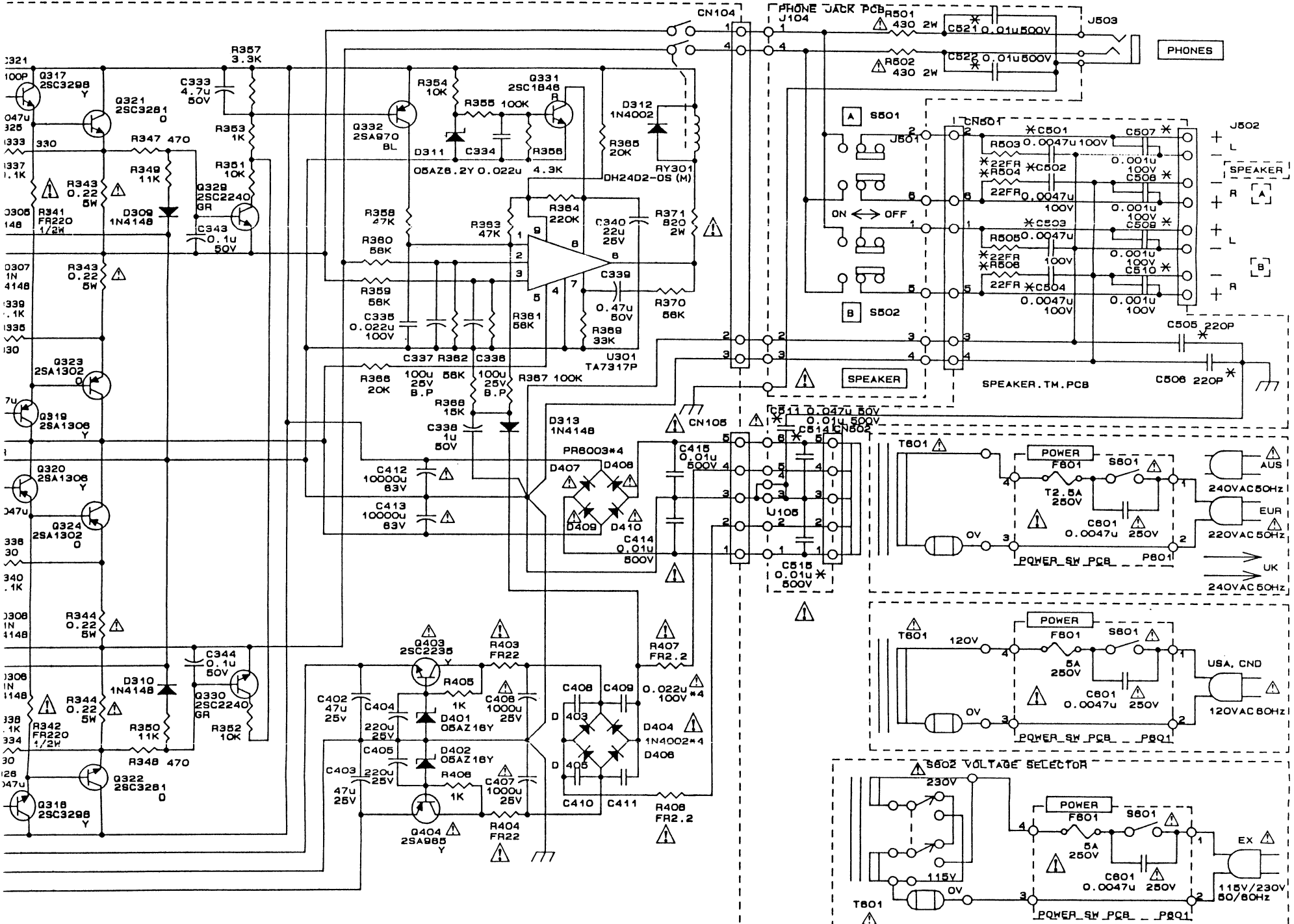
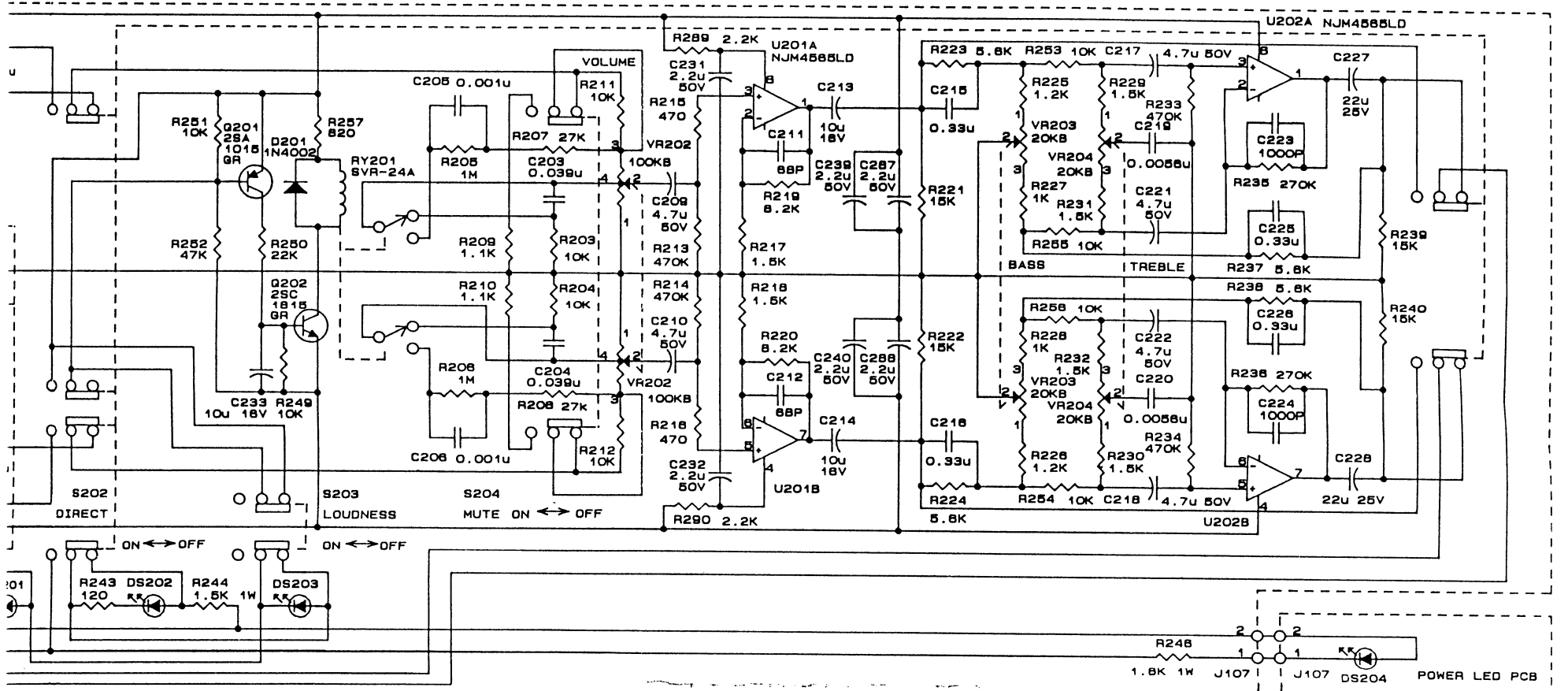

**** NOTE ****

- ALL RESISTORS ARE 1/8W CARBON FILM RESISTOR UNLESS OTHERWISE LISTED. RESISTANCE UNIT IS IN OHM. K=1,000 M=1,000,000 1/2W: METAL OR METAL OXIDE 1/2W. 1/25: SOLDER 1/2W. 1/2W: FUSE RESISTOR 1/2W. 10W: CEMENT RESISTOR 10W.
- ALL CAPACITORS ARE 50V CERAMIC CAPACITOR UNLESS OTHERWISE LISTED. CAPACITANCE LESS THAN 1 ARE EXPRESS IN UM. AND GREATER THAN 1 IN OF.

**** IMPORTANT SAFETY NOTICE ****

COMPONENTS IDENTIFIED BY Δ MARK HAVE SPECIAL CHARACTERISTICS IMPORTANT FOR SAFETY.

WHEN REPLACING ANY OF THESE COMPONENTS USE ONLY MANUFACTURER'S SPECIFIED PARTS.

1331
Stereo Amplifier A-X3000