

The home of the turntable

**THE VINYL ENGINE®**

For more turntable manuals and setup information  
please visit [www.vinylengine.com](http://www.vinylengine.com)

# Service Manual

Quartz Direct Drive Automatic Turntable System

## SL-QL5

[M],[MC]



**TAP** is the standard mark for the "P-mount" plug-in-connector system. Products carrying this mark are inter-changeable and compatible with each other.

\*The cartridge shown here is an option.

### Areas

- \*[M] is available in U.S.A.
- \*[MC] is available in Canada.

## Specifications

Specifications are subject to change without notice for further improvement.  
Weight and dimensions shown are approximate.

### ■ General

<b>Power supply:</b>	120 V AC, 60 Hz
<b>Power consumption:</b>	10W
<b>Dimensions:</b> (W×H×D)	43 × 8.8 × 35 cm (16-59/64" × 3-1/2" × 13-25/32") 43 × 38.5 × 35 cm (16-59/64" × 15-23/64" × 13-25/32") (Maximum height when dust cover is open.)
<b>Weight:</b>	5.1 kg ( 11.2lb.)

### ■ Turntable section

<b>Type:</b>	Direct drive Fully automatic turntable
<b>Features:</b>	Auto start/Auto lead-in Auto return Auto stop Repeat play Auto speed select Manual speed selection possible Auto size select Record presence detection
<b>Drive method:</b>	Direct drive
<b>Motor:</b>	Brushless DC motor
<b>Drive control method:</b>	Quartz-phase-locked control

<b>Turntable platter:</b>	Aluminum die-cast Diameter 30 cm (12")
<b>Turntable speeds:</b>	33-1/3 rpm and 45 rpm Auto speed select (Manual selection possible)
<b>Wow and flutter:</b>	0.012% WRMS* 0.025% WRMS (JIS C5521) ±0.035% peak (IEC 98A Weighted)
* Measured by obtaining signal from built-in frequency generator of motor assembly.	
<b>Rumble:</b>	-56 dB (IEC 98A Unweighted) -78 dB (IEC 98A Weighted)

### ■ Tonearm section

<b>Type:</b>	Dynamic balanced type Linear tracking tonearm 4-pivot gimbal suspension
<b>Effective length:</b>	10.5 cm (4-1/8")
<b>Tracking error angle:</b>	Within ±0.1°
<b>Effective mass:</b>	9 g (including cartridge)
<b>Resonance frequency:</b>	12 Hz
<b>Tonearm drive motor:</b>	DC motor
<b>Phono cable capacitance:</b>	150 pF

# Technics

Matsushita Engineering and  
Service Company  
50 Meadowland Parkway,  
Secaucus, New Jersey 07094

Panasonic Hawaii Inc.  
91-238 Kauhū St. Ewa Beach  
P.O. Box 774  
Honolulu, Hawaii 96808-0774

Panasonic Sales Company,  
Division of Matsushita Electric  
of Puerto Rico, Inc.  
Ave. 65 De Infanteria, KM 9.7  
Victoria Industrial Park  
Carolina, Puerto Rico 00630

Matsushita Electric  
of Canada Limited  
5770 Ambler Drive, Mississauga,  
Ontario, L4W 2T3

## ■ CONTENTS

	Page		
SAFETY PRECAUTION .....	2	RESISTORS AND CAPACITORS .....	13
LOCATION OF CONTROLS .....	3	REPLACEMENT PARTS LIST .....	14
DISASSEMBLY INSTRUCTION .....	4	EXPLODED VIEWS .....	15
HOW TO SET THE TONEARM DRIVE ROPE .....	7	CIRCUIT BOARDS AND WIRING	
HOW TO REPLACE CHIPS .....	8	CONNECTION DIAGRAM .....	18
MEASUREMENTS AND ADJUSTMENT .....	8	SCHEMATIC DIAGRAM .....	21
TROUBLE SHOOTING .....	10	BLOCK DIAGRAM .....	24
FUNCTION OF TERMINAL (MN 1425 FPC) .....	13	PACKING .....	26

## ■ SAFETY PRECAUTION

1. Before servicing, unplug the power cord to prevent an electric shock.
2. When replacing parts, use only manufacturer's recommended components for safety.
3. Check the condition of the power cord. Replace if wear or damage is evident.
4. After servicing, be sure to restore the lead dress, insulation barriers, insulation papers, shields, etc.
5. Before returning the serviced equipment to the customer, be sure to make the following insulation resistance test to prevent the customer from being exposed to a shock hazard.

### ● INSULATION RESISTANCE TEST

1. Unplug the power cord and short the two prongs of the plug with a jumper wire.
2. Turn on the power switch.
3. Measure the resistance value with ohmmeter between the jumpered AC plug and each exposed metal cabinet part, such as screwheads antenna, control shafts, handle brackets, etc. Equipment with antenna terminals should read between  $3M\Omega$  and  $5.2M\Omega$  to all exposed parts. (Fig. A) Equipment without antenna terminals should read approximately infinity to all exposed parts. (Fig. B)

**Note:** Some exposed parts may be isolated from the chassis by design. These will read infinity.

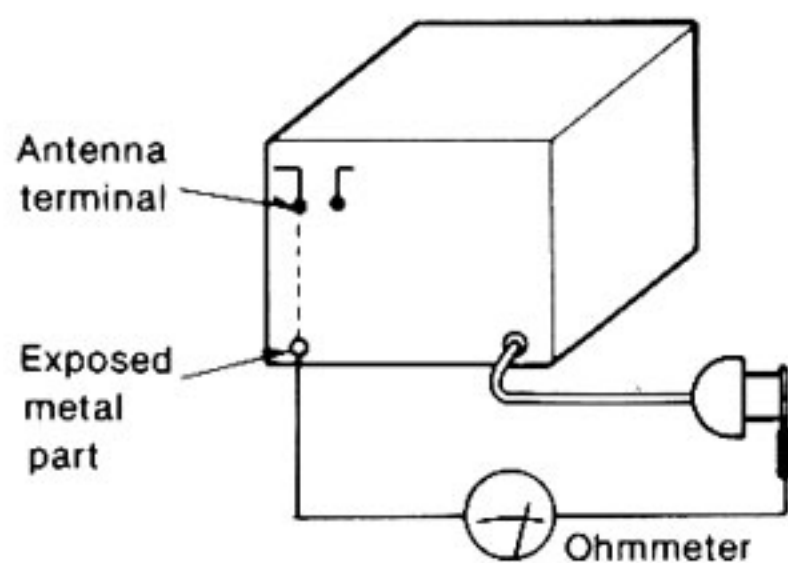

(Fig. A)

Resistance =  $3M\Omega - 5.2M\Omega$

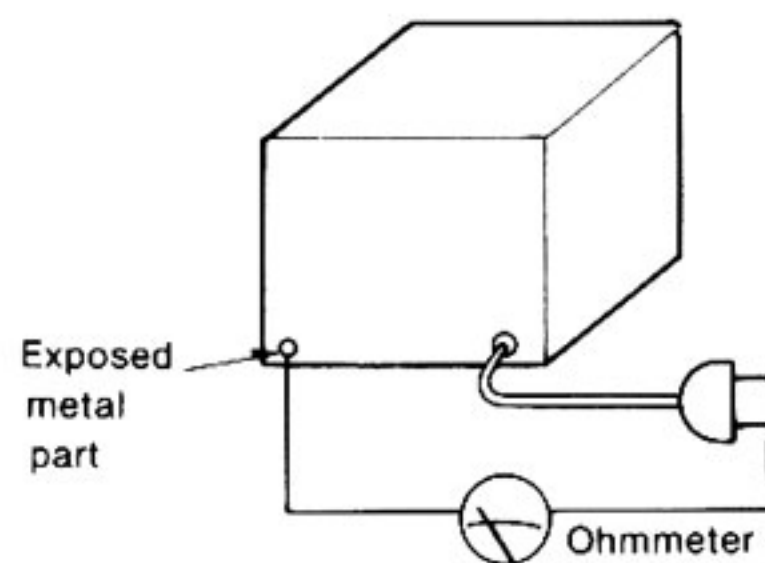

(Fig. B)

Resistance = Approx  $\infty$

4. If the measurement is outside the specified limits, there is a possibility of a shock hazard. The equipment should be repaired and rechecked before it is returned to the customer.

# ■ LOCATION OF CONTROLS

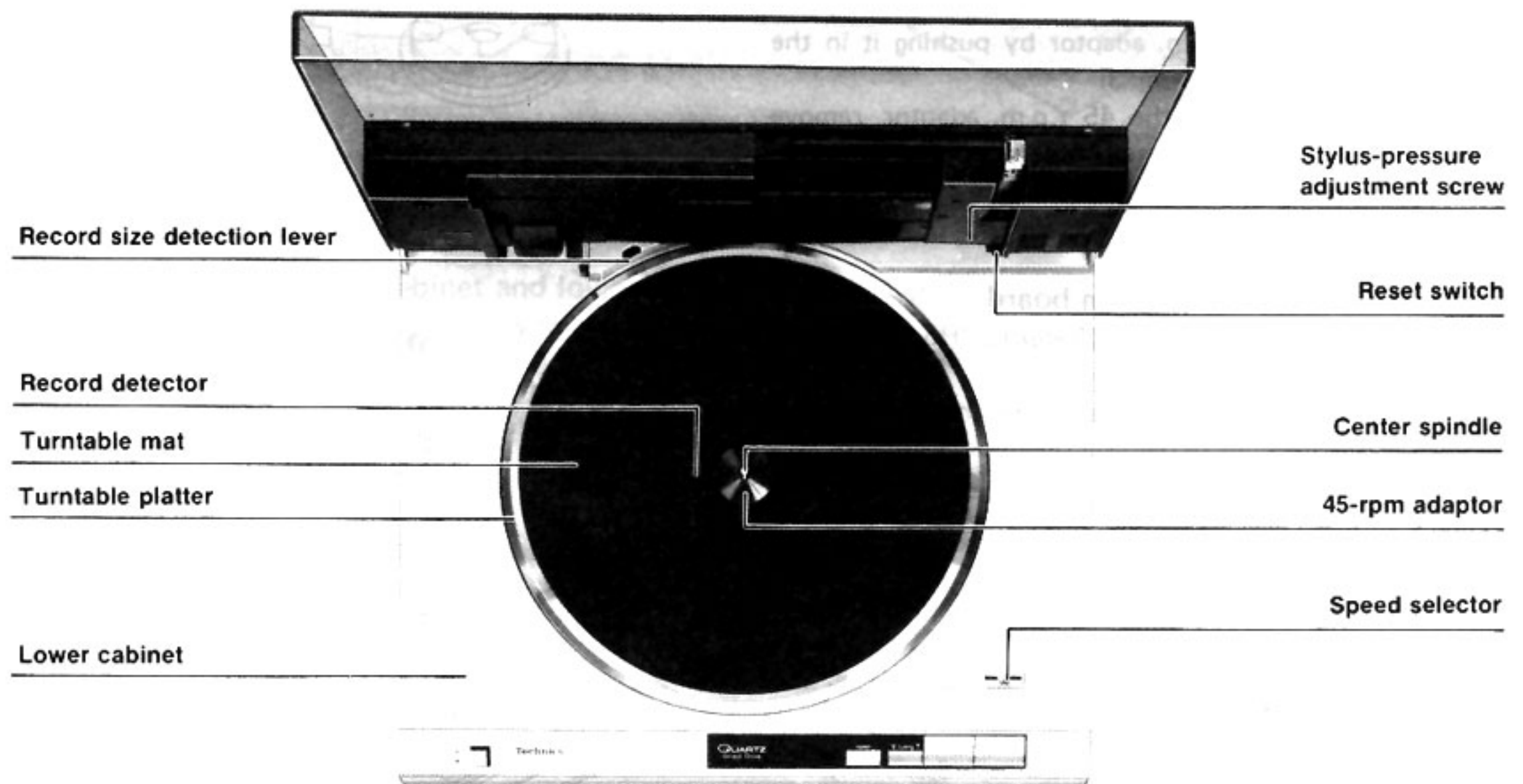
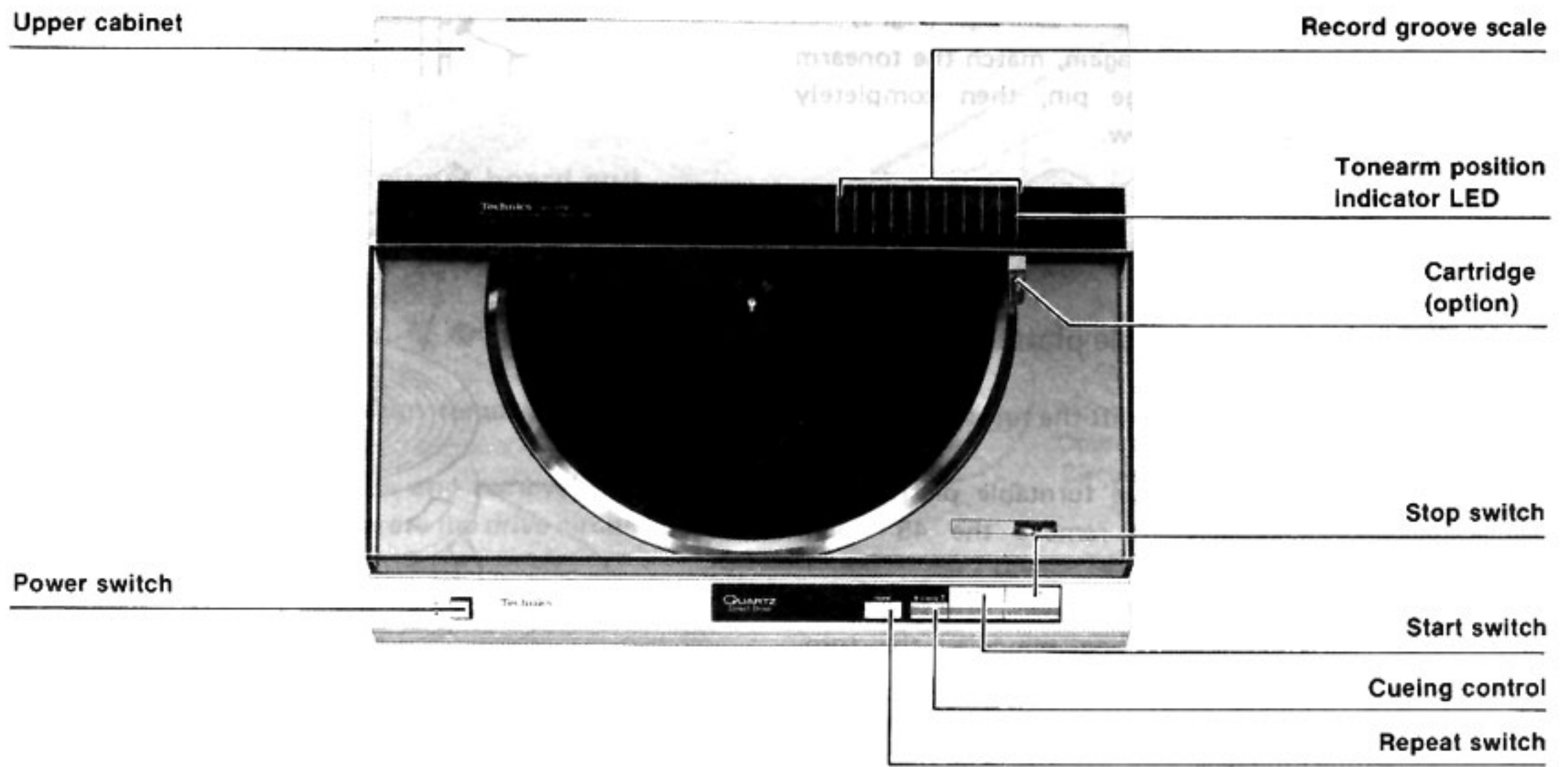



## ■ DISASSEMBLY INSTRUCTIONS

### ● How to remove the cartridge

1. Open the upper cabinet.
2. Remove the setscrew and pull out the cartridge. (Fig. 1)
3. When attaching the cartridge again, match the tonearm connector with the cartridge pin, then completely insert it and tighten the setscrew.

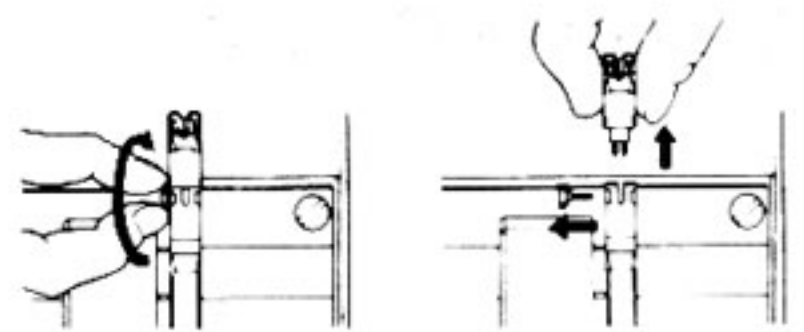

Fig. 1

### ● How to remove the turntable platter

1. Open the upper cabinet.
2. Remove the turntable mat and lift the turntable platter. (Fig. 2)

**Note:** (1) When removing the turntable platter, it is not necessary to remove the 45 r.p.m. adaptor.

- (2) The turntable platter is tight fitted on to the center spindle. When removing the turntable platter, take care not to give damage to the upper cabinet, arm motor cover and tonearm cover.

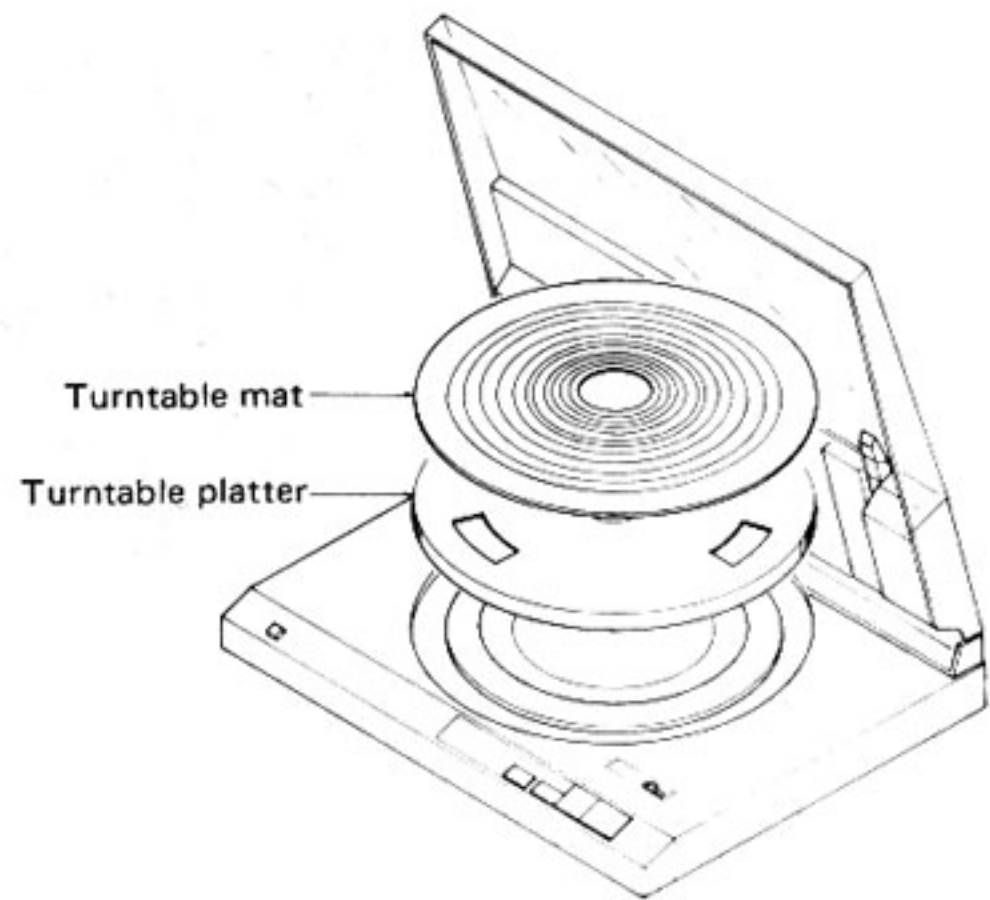

Fig. 2

### ● How to remove the 45 r.p.m. adaptor

1. Remove the turntable platter. (Refer to "How to remove the turntable platter.")
2. The 2 adaptor claws fit into the turntable platter, and so remove the 45 r.p.m. adaptor by pushing it in the direction of the arrow. (Fig. 3)

**Note:** When removing the 45 r.p.m. adaptor, remove the turntable platter, otherwise the 45 r.p.m. adaptor claws will be broken.

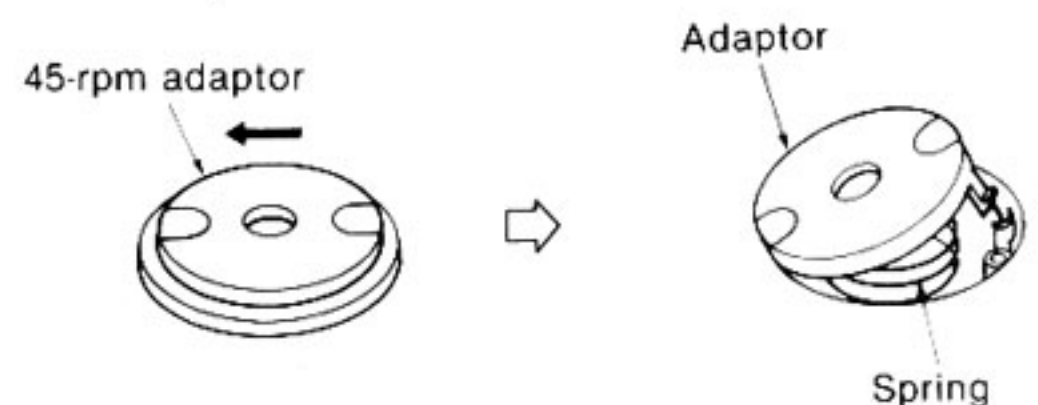

Fig. 3

### ● How to remove the bottom board

1. Remove the turntable platter. (Refer to "How to remove the turntable platter.")
2. Close the upper cabinet and turn over the unit on a soft cloth taking care not to damage the upper cabinet.
3. Remove the 6 setscrews (Fig. 4 ① ~ ⑥), 4 Insulators and 4 springs (Fig. 4).

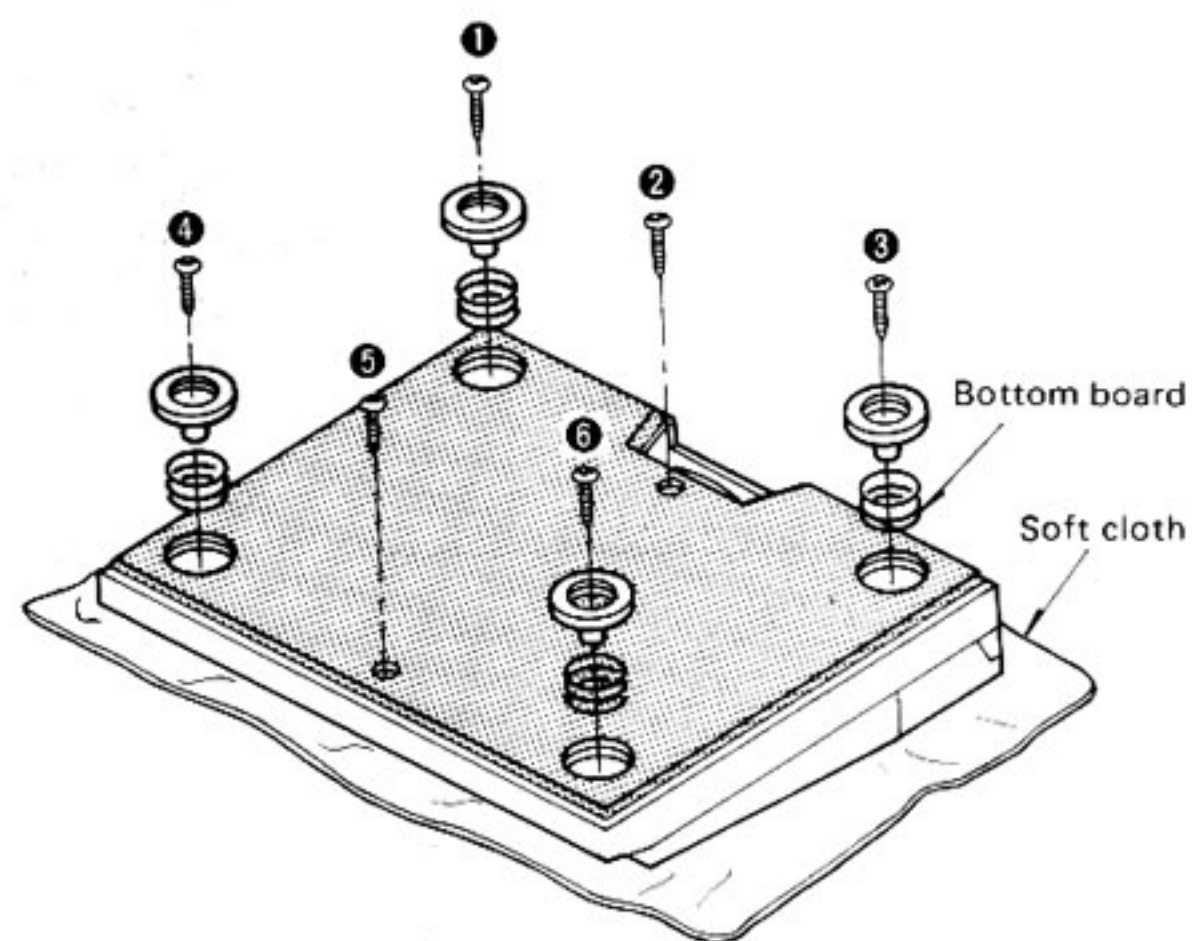

Fig. 4

• **How to remove the operation circuit board**

1. Remove the bottom board. (Refer to "How to remove the bottom board.")
2. Remove the 7 operation circuit board setscrews (Fig. 5: ⑦~⑬) and the stopper.

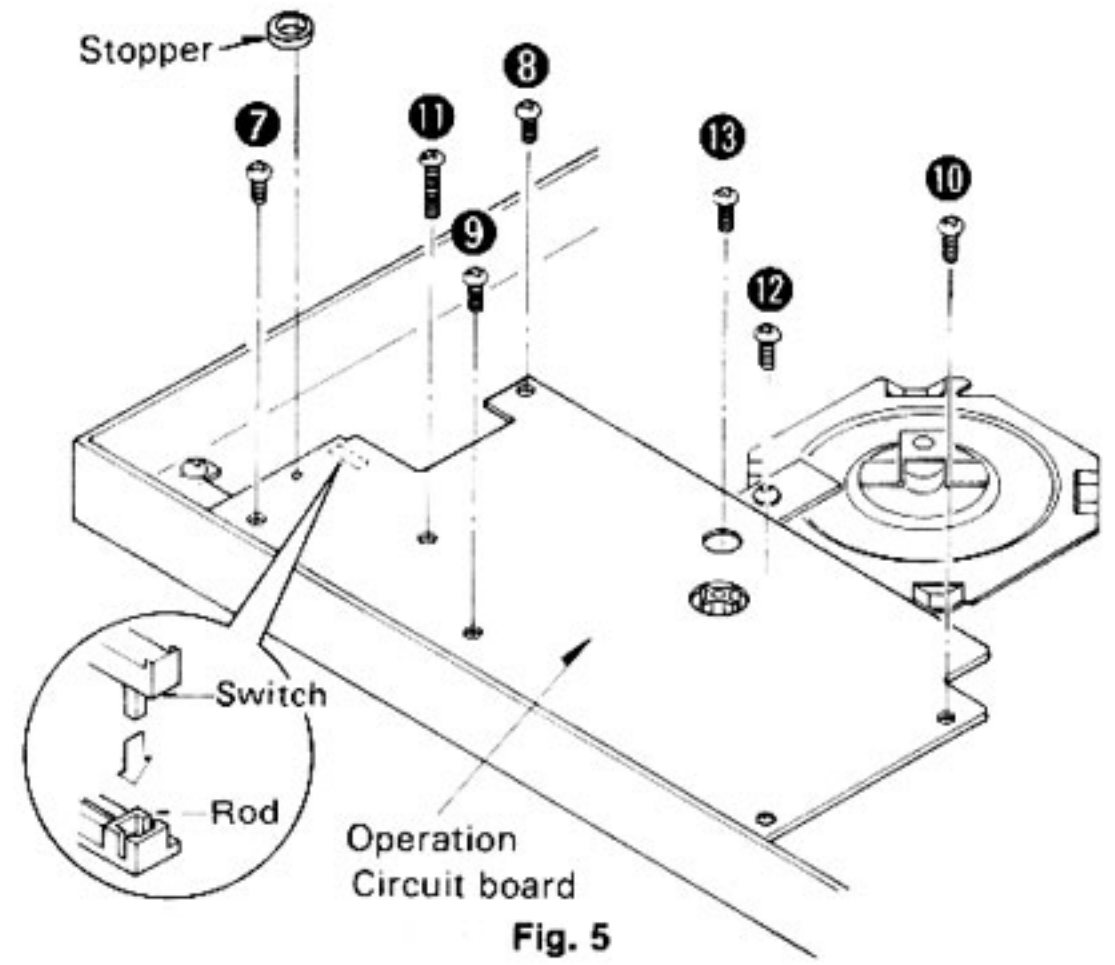

Fig. 5

• **How to remove the drive circuit board and stator frame**

1. Remove the operation circuit board (Refer to "How to remove the operation circuit board.")
2. Remove the 4 setscrews (Fig. 6: ⑰~⑳) of the stator frame.
3. Pull out connector CN101, then remove the drive circuit board with stator frame.
4. Cut off the stopper by nippers and remove the 4 setscrews (Fig. 7: ㉑~㉔) to separate the drive circuit board and stator frame.

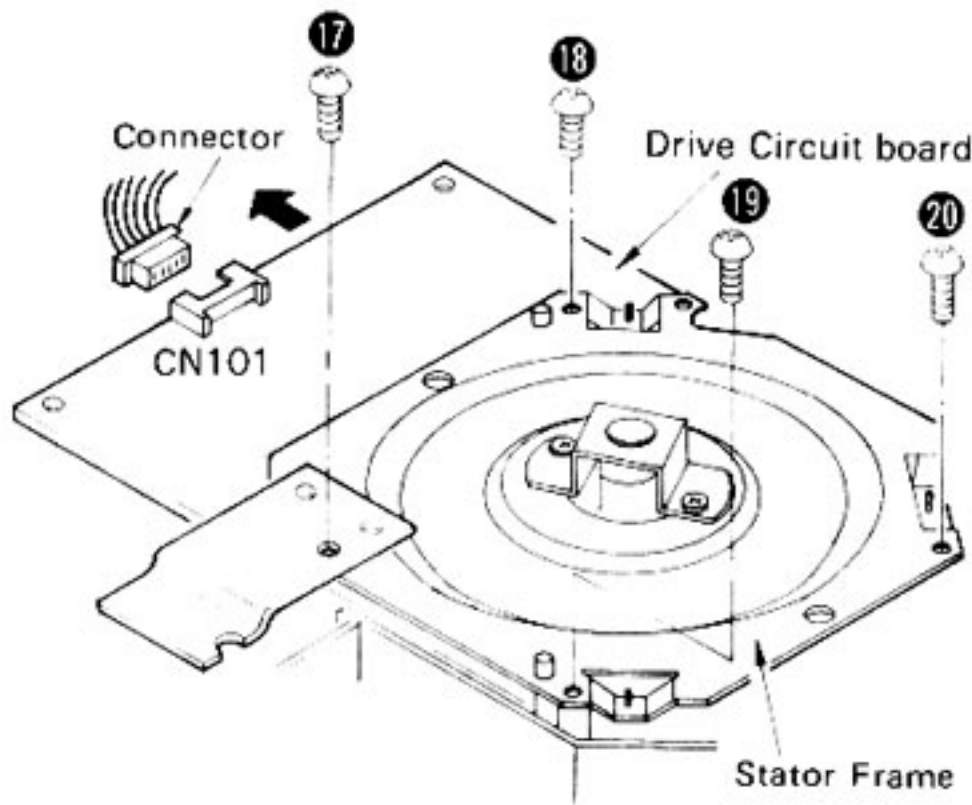

Fig. 6

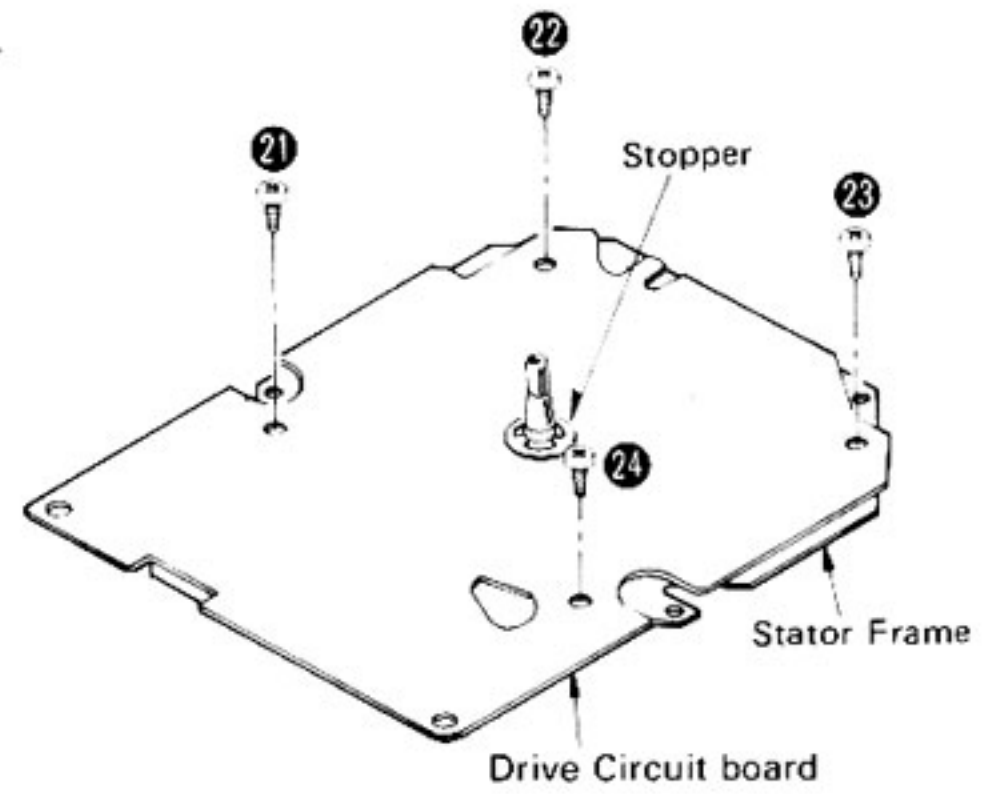

Fig. 7

• **How to separate the upper cabinet and lower cabinet**

1. Remove the bottom board. (Refer to "How to remove the bottom board.")
2. Pull out the 2 connectors (CN301, CN401) from the operation circuit board. (Fig. 8)
3. Remove the 4 hinge setscrews (Fig. 9: ㉕~㉔) and the phono output jack.
4. Release the claws and slowly lift the lower cabinet to separate it from the upper cabinet.

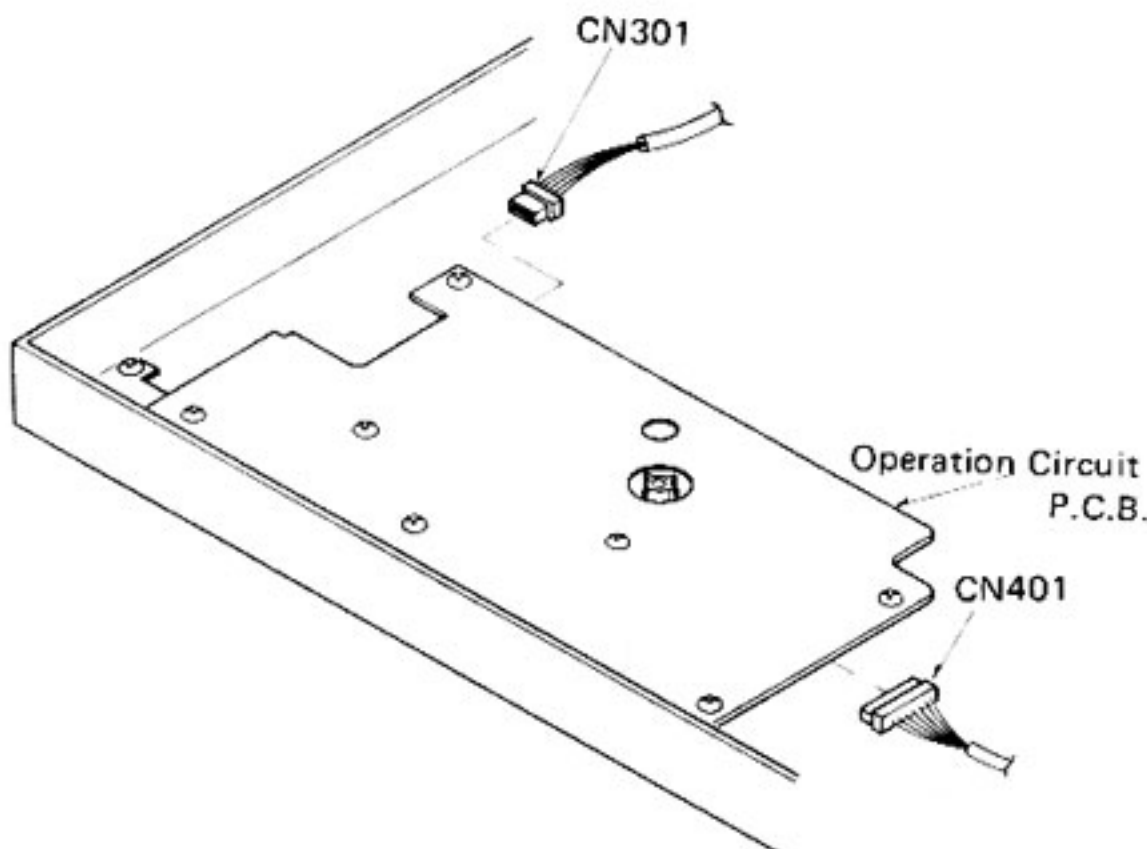

Fig. 8

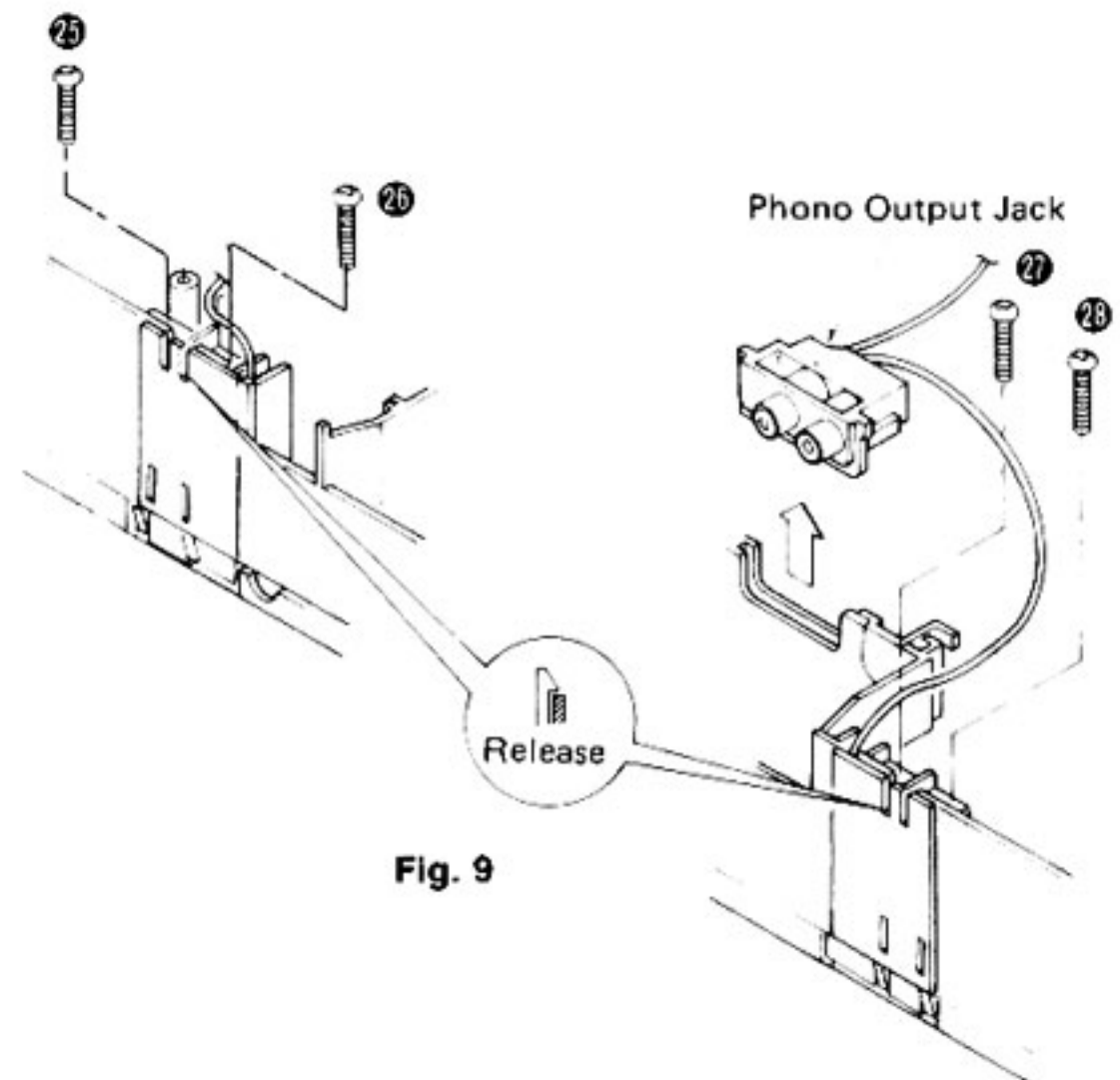

Fig. 9



• **How to remove the dust cover**

1. Open the upper cabinet.
2. Remove the 4 setscrews (Fig. 10: 29~32).
3. Remove the 5 dust cover setscrews (Fig. 10: 33~35) and Fig. 11: 36, 37).

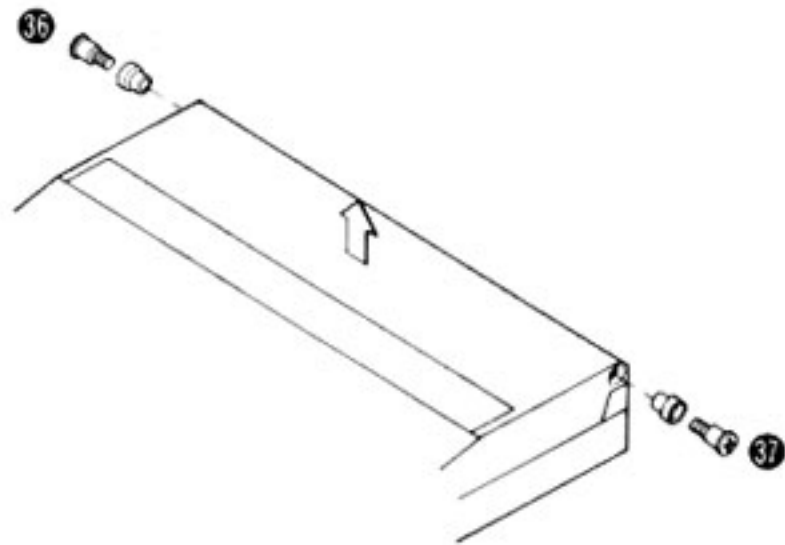

Fig. 11

• **How to remove the tonearm position detecting circuit board.**

1. Open the upper cabinet and remove the arm motor cover. (Refer to "How to remove the dust cover.")
2. Remove the tonearm position detecting circuit board setscrew (Fig. 10: 36).
3. Release the each 2 claws and remove the tonearm position detecting circuit board and the rest switch (S 601). (Fig. 10: (A) (B))

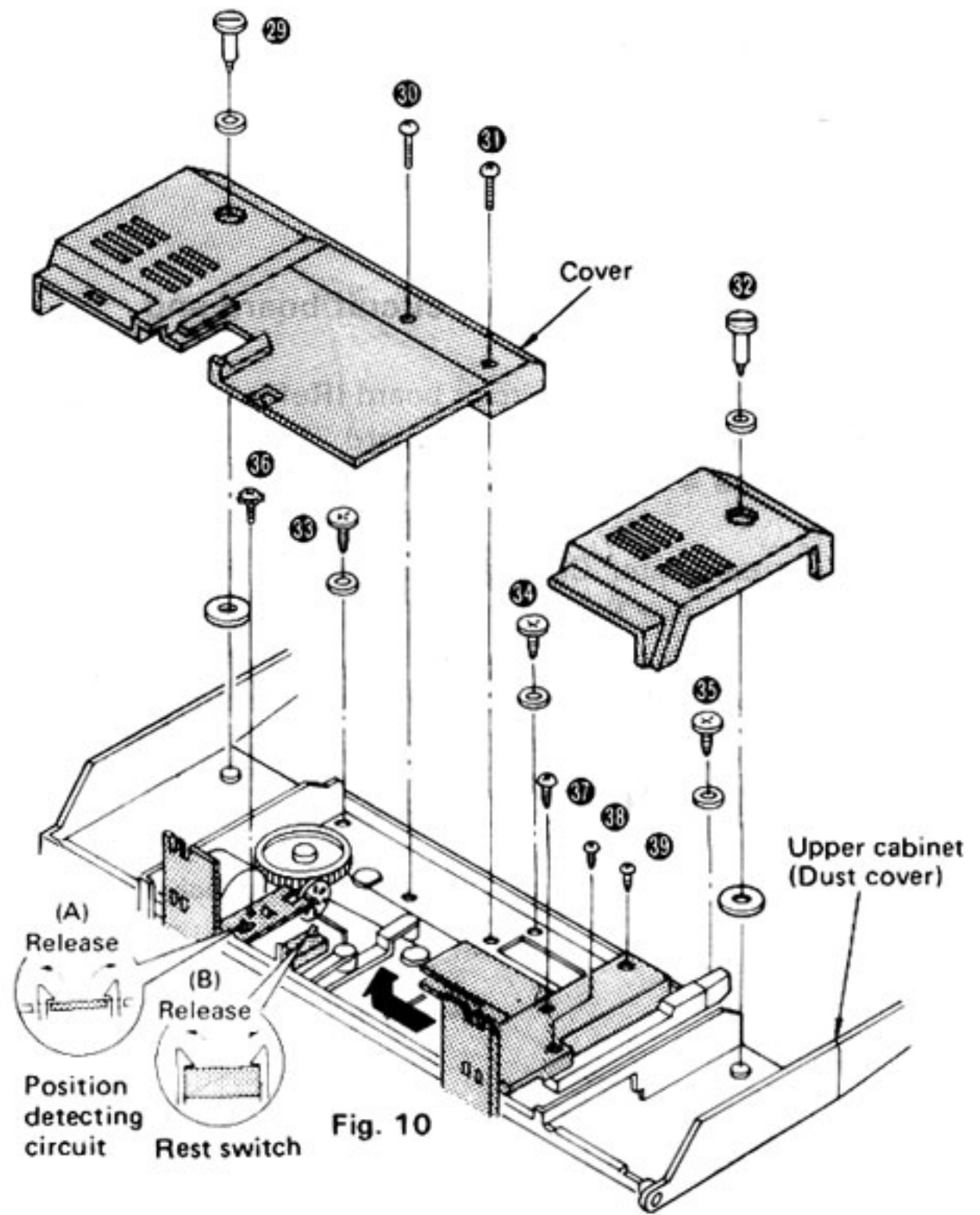

Fig. 10

• **How to remove the tonearm**

1. Separate the upper cabinet and lower cabinet. (Refer to "How to separate the upper cabinet and lower cabinet.")
2. Remove the tonearm cover setscrew (Fig. 10: 37 ~ 39) and tonearm cover.
3. Unsolder the 5 lead wires (Fig. 11).
4. Remove the tonearm setscrew (Fig. 12: 40).

• **How to remove the cueing control ass'y**

1. Remove the tonearm cover. (Refer to "How to remove the tonearm" Item 2)
2. Unsolder the 2 lead wires from the cueing plunger (Fig. 11)
3. Remove the 2 cueing control ass'y setscrews (Fig. 11: 41, 42), and the cueing control ass'y can be removed in the direction of the arrow A.

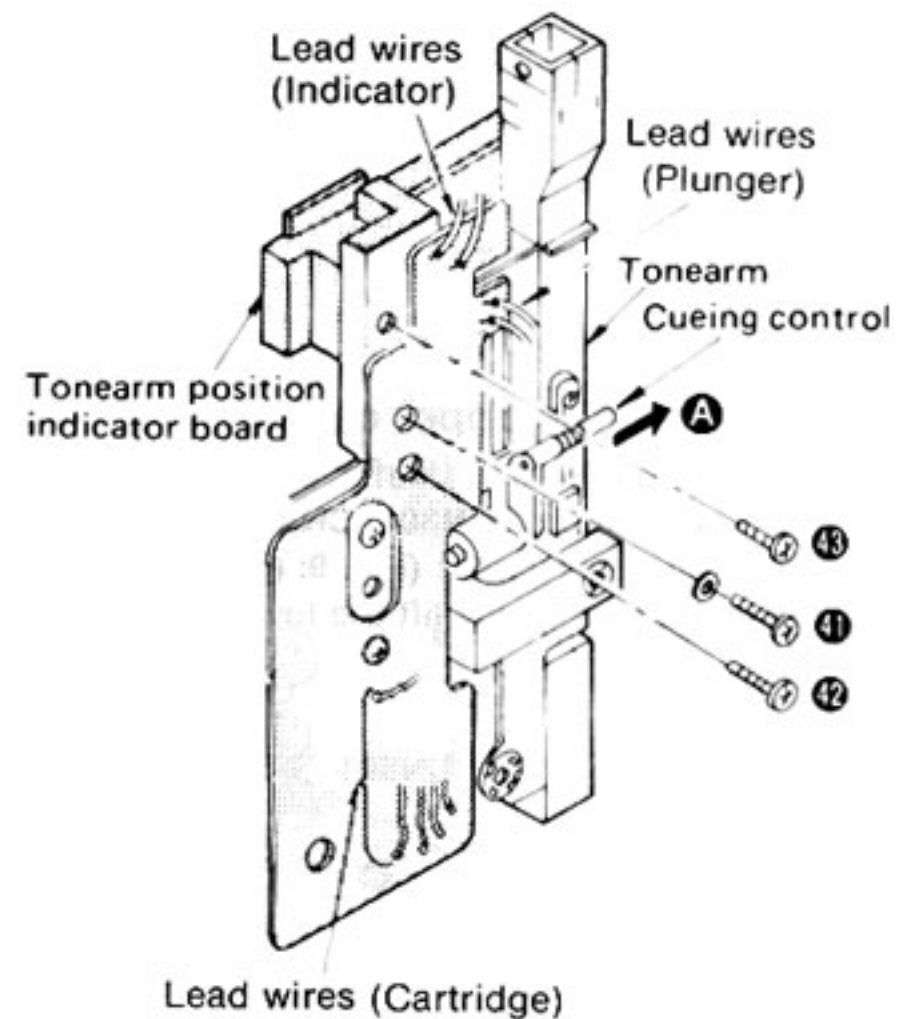

Fig. 11

• **How to remove the tonearm position indicator board**

1. Remove the dust cover and tonearm cover. (Refer to "How to remove the dust cover" and "How to remove the tonearm Item 2)
2. Unsolder the 2 lead wires from the indicator (Fig. 11)
3. Remove the tonearm position indicator board setscrew (Fig. 11: 43).

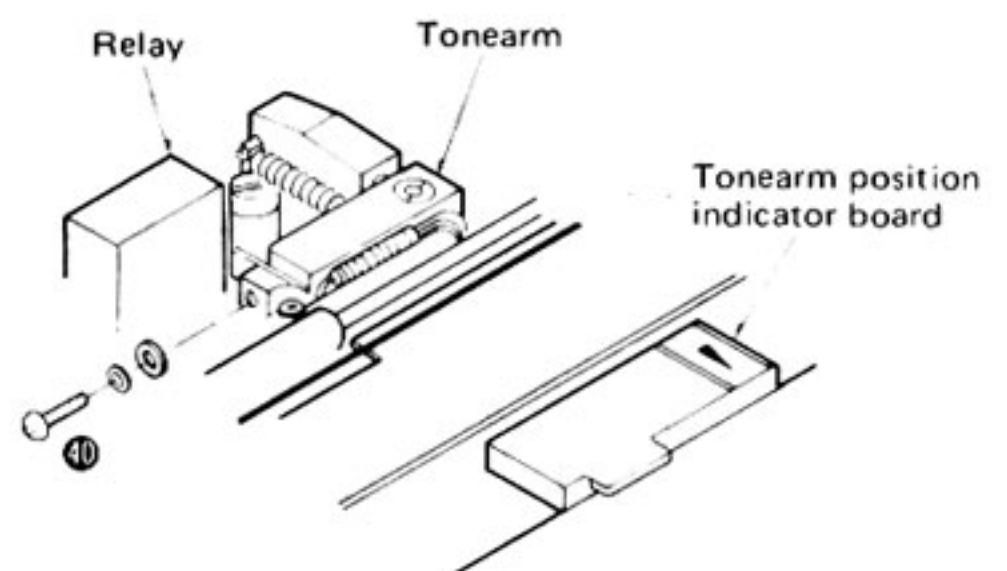

Fig. 12

- **How to remove the Hall element**

1. Remove the turntable platter.
2. Remove the terminal solder by use of solder sucker.
3. Hold the Hall element with a tweezers and remove it while touching the soldering iron to the terminal.

(Fig. 13)

**Note:** Fit the Hall element with the part No. print up. The reverse in terminal position is allowable provided that the printed side is up.

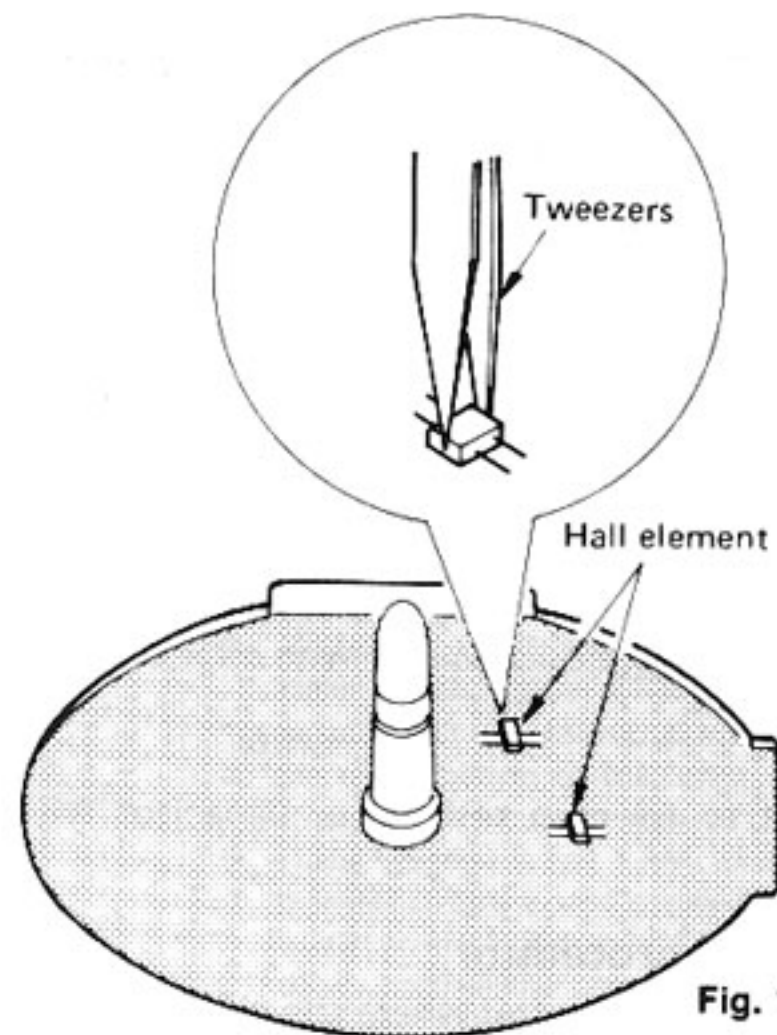

Fig. 13

- **How to remove the cabinet (Reset) switch**

1. Remove the bottom board (Refer to "How to remove the bottom board.")
2. Completely open the upper cabinet.
3. Remove the cabinet switch setscrew (Fig. 14: 44).

**Note:** When fitting the cabinet switch, be sure to open the upper cabinet.

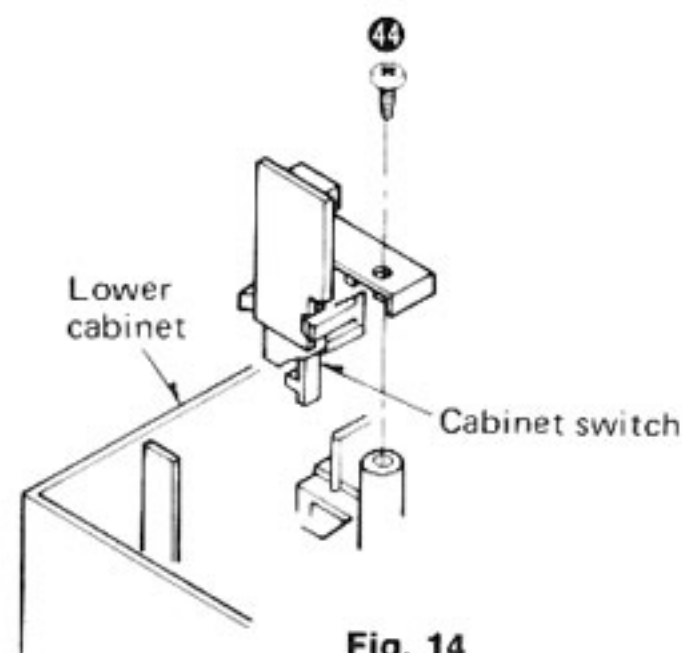

Fig. 14

## ■ HOW TO SET THE TONEARM DRIVE ROPE

Set the rope according to the following procedure.

1. Open the upper cabinet and remove the cartridge.
2. Remove the arm motor cover and tonearm cover.
3. Detach the arm drive wheel "C" ring (43) and washer (44), and remove the drive wheel. (See Fig. 15)
4. Turn over the arm drive wheel and set the rope in the order of 1 ~ 2. (Fig. 16)
5. Holding the rope set over the arm drive wheel with the hand, set the rope over the wheels in the order of 3 ~ 5 in Fig. 17.
6. After setting the rope, rotate the worm gear by hand until the tonearm matches the rope connector.
7. Rotate the worm gear by hand and check that the tonearm operates, and then fit the washer (44) and "C" ring (43) in place.

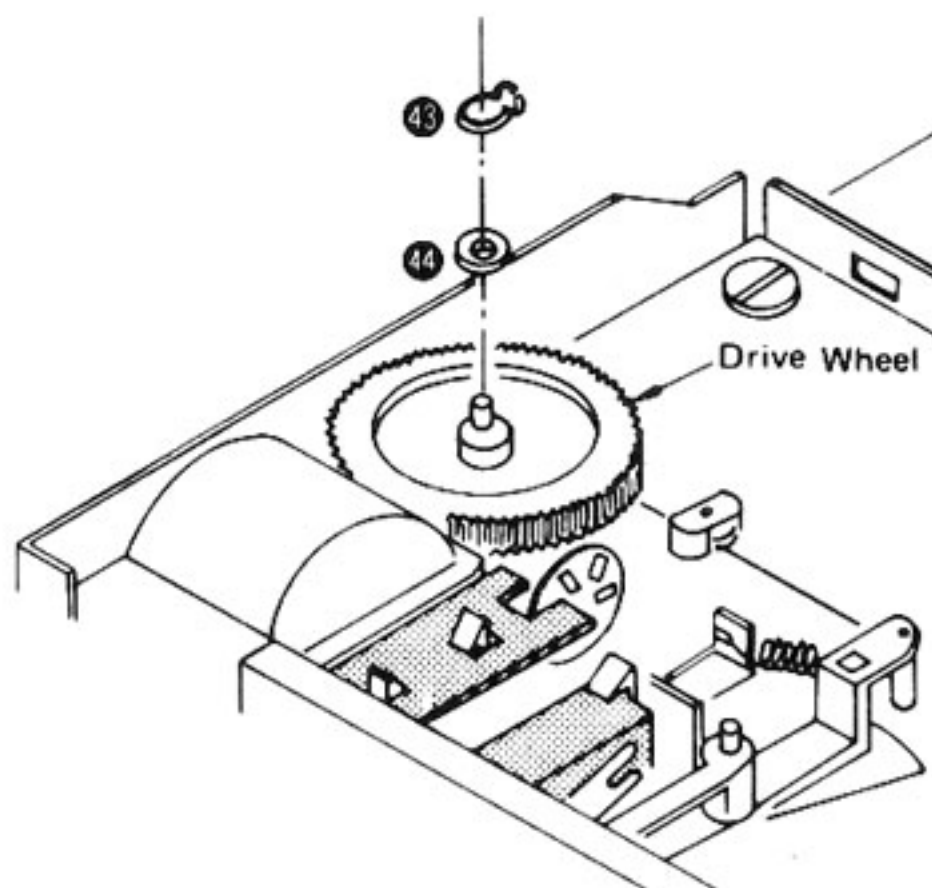

Fig. 15

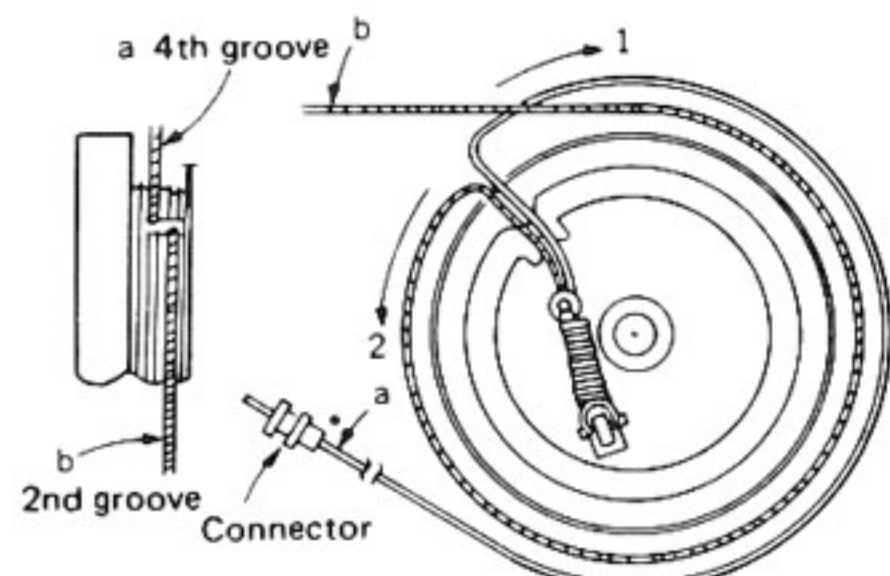

Fig. 16

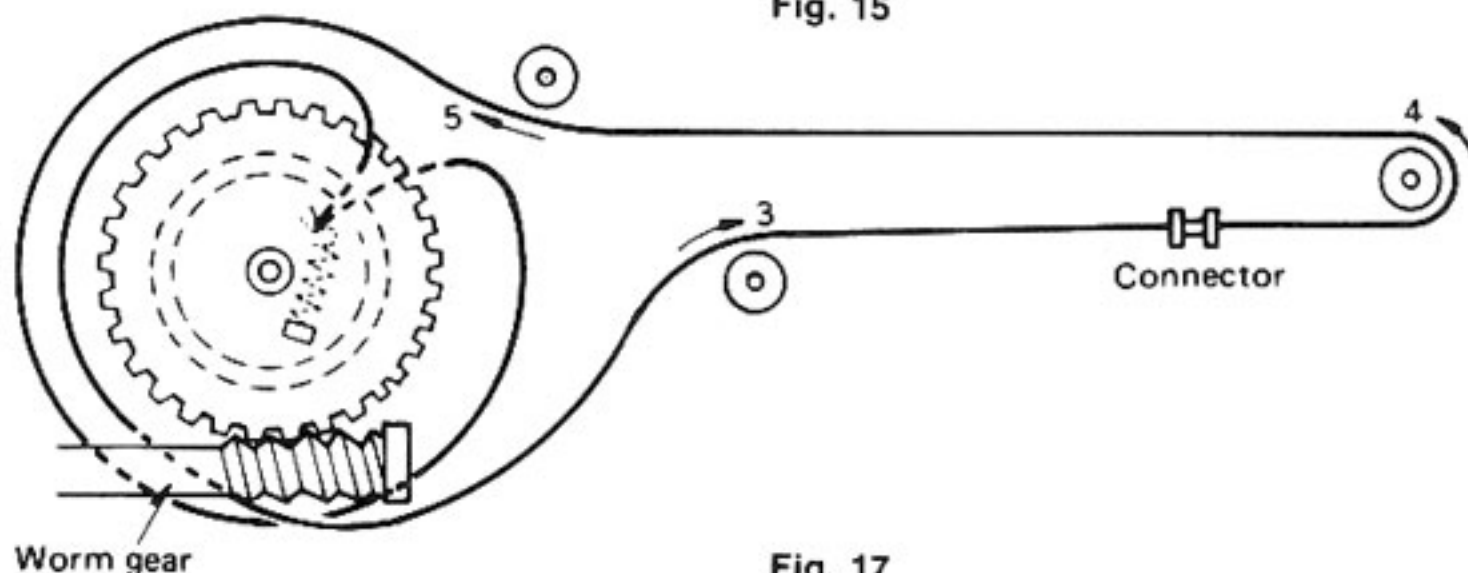

Fig. 17



## ■ HOW TO REPLACE CHIPS

(Resistor, capacitor and jumper)

### ● Removing procedure

1. Completely remove the solder from both ends of the chip by use of solder sucker.
2. Touch the soldering iron to the end of the chip as shown in Fig. 18, then turn the tweezers in the direction of the arrow.

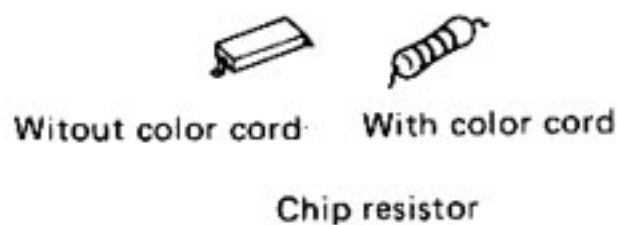

Do not re-use chip resistor or capacitor without color cord.

### ● Replacing procedure

1. Place solder on the foil where the chip is fitted. Then solder the chip by holding the soldering iron as shown in Fig. 19.

#### Note:

1. If the chip jumper is removed, connect a coated lead wire to the part. (See Fig. 20). Chip jumper is marked with "J" on the printed circuit board.

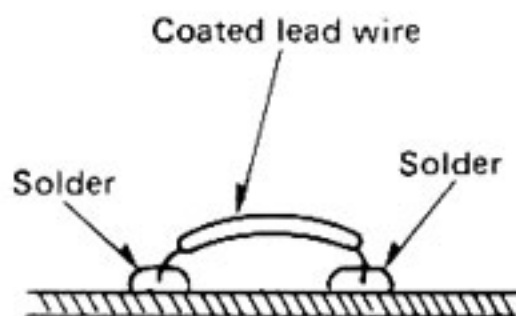

Fig. 20

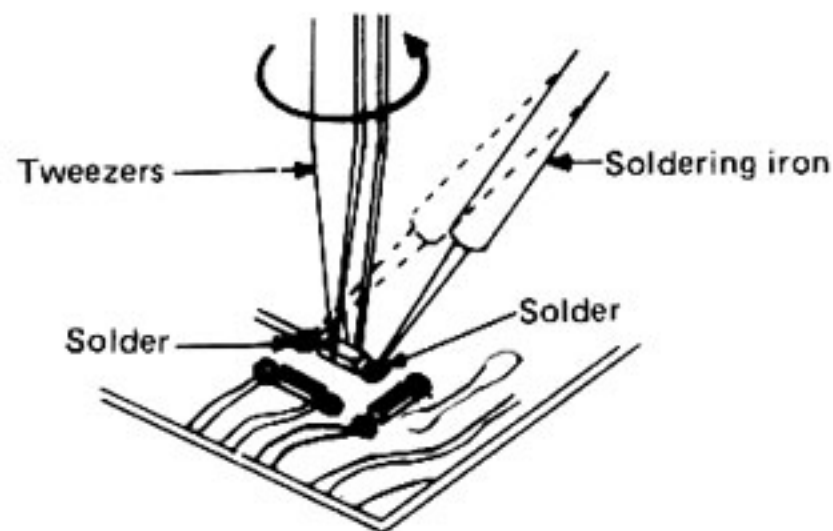

Fig. 18

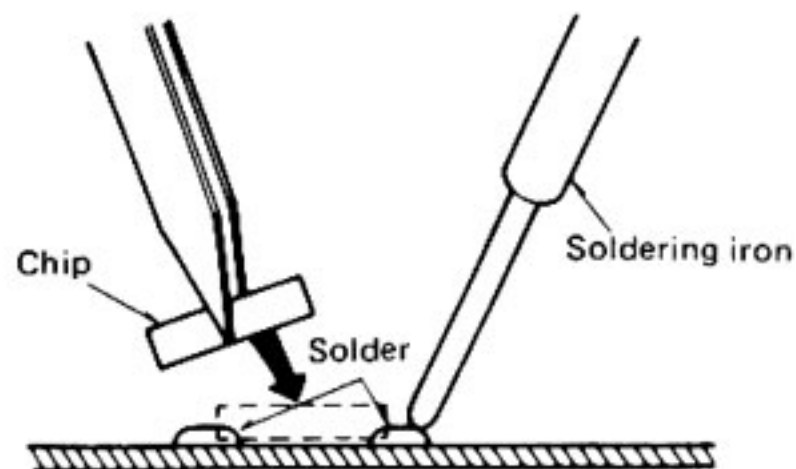

Fig. 19

### ● Note for replacing chips

1. Do not heat the chip more than 3 seconds.
2. Do not rub the electrode against the chip.
3. Use the tweezers with care not to damage the surface of the chip.
4. It is desirable to use a pencil type soldering iron. And use soldering iron less than 60W.

## ■ MEASUREMENTS AND ADJUSTMENT

### ● Instruments used

1. Oscilloscope
2. DC voltmeter
3. 30cm record
4. Screwdriver

Step	Item	Preparations for adjustment	Adjusting portion	Adjusting method
1	Start position	<ol style="list-style-type: none"> <li>1. Put 30cm record on turntable mat and close upper cabinet.</li> <li>2. Turn the power switch on.</li> <li>3. Push the "Start" switch.</li> </ol>	Start position adjusting screw. (Fig. 21)	<ol style="list-style-type: none"> <li>1. Turn the start position adjusting screw. If it descends between tunes, turn the screw clockwise. If it descends outside the disc, turn the screw counterclockwise.</li> </ol>
2	Clock frequency	<ol style="list-style-type: none"> <li>1. Connect lead wire with clip to IC 301 pin ⑦ and pin ⑳ of operation circuit board.</li> <li>2. Connect oscilloscope to IC 301 pin ⑥.</li> </ol>	VR 301 (Fig. 22)	<ol style="list-style-type: none"> <li>1. Set power switch to "on".</li> <li>2. Adjust VR 301 so that the cycle output waveform is <math>30 \mu\text{sec} \pm 1 \mu\text{sec}</math>. (Fig. 23)</li> </ol>

Step	Item	Preparations	Parts adjusted	Procedure
3	<b>Tonearm offset angle</b>	<ol style="list-style-type: none"> <li>1. Open the upper cabinet and hold the cabinet switch with tape.</li> <li>2. Close the upper cabinet.</li> </ol>	Adjusting screw <b>(Fig. 24)</b>	<ol style="list-style-type: none"> <li>1. Turn the power switch on and push the start switch to shift the tonearm inward.</li> <li>2. Open the upper cabinet.</li> <li>3. Turn the adjusting screw so that the arm center matches the V-groove of the lift bar.</li> </ol>
4	<b>Servo gain and offset voltage</b>	<ol style="list-style-type: none"> <li>1. Open the upper cabinet and hold the cabinet switch with the tape.</li> <li>2. Close the upper cabinet.</li> <li>3. Connect the DC voltmeter to CN301 terminal ③ and ground terminal.</li> <li>4. Remove the Label of the tonearm cover.</li> </ol>	VR501 (Servo gain) P.C.B. (Offset voltage) <b>(Fig. 25)</b>	<ol style="list-style-type: none"> <li>1. Turn the power switch on and push the start switch to shift the tonearm inward.</li> <li>2. Open the upper cabinet.</li> <li>3. Completely shift the tonearm to the right. Then, adjust VR501 so that the voltage is 3.6V. <b>(Servo gain)</b></li> <li>4. Set the tonearm to the center and make sure that the output voltage is 1.8V.</li> <li>5. If the voltage is not 1.8V, loosen the printed circuit board screw and move the board to the right or left with a screwdriver so that the output voltage becomes 1.8V. After the adjustment, tighten the printed circuit board screw. <b>(Offset adjustment)</b></li> </ol>

• Adjustment points

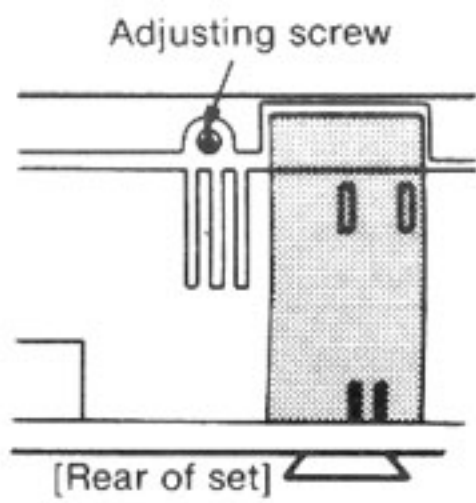

Fig. 21

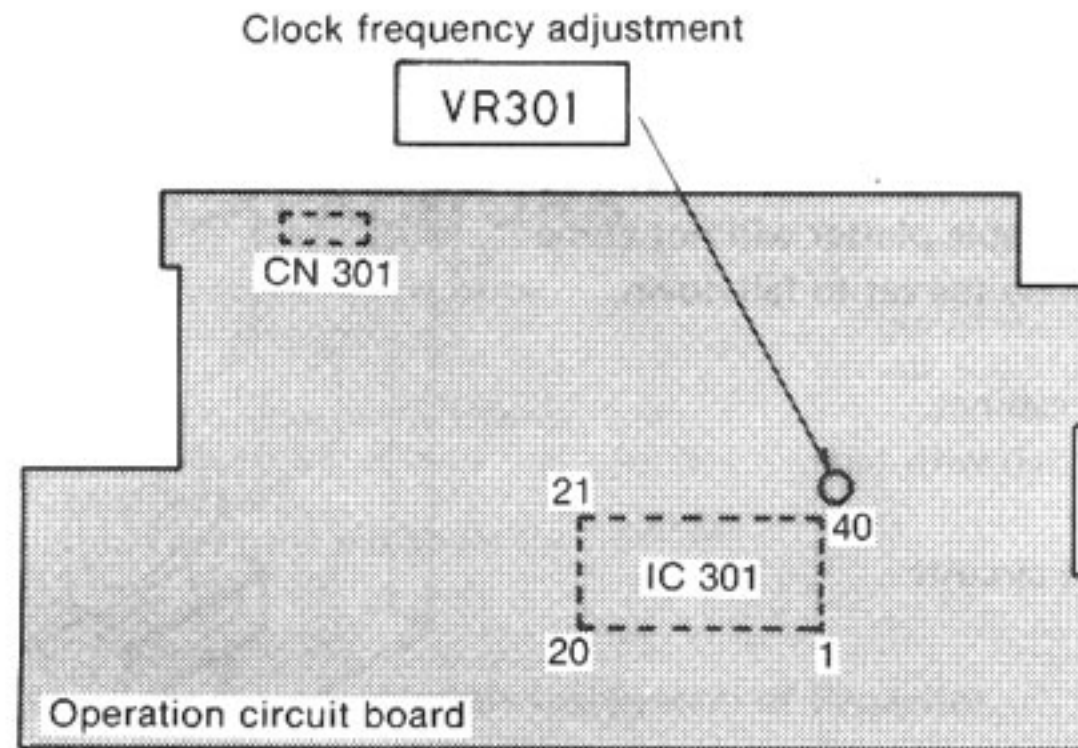

Fig. 22

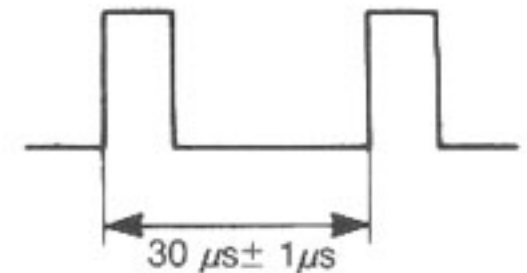

Fig. 23

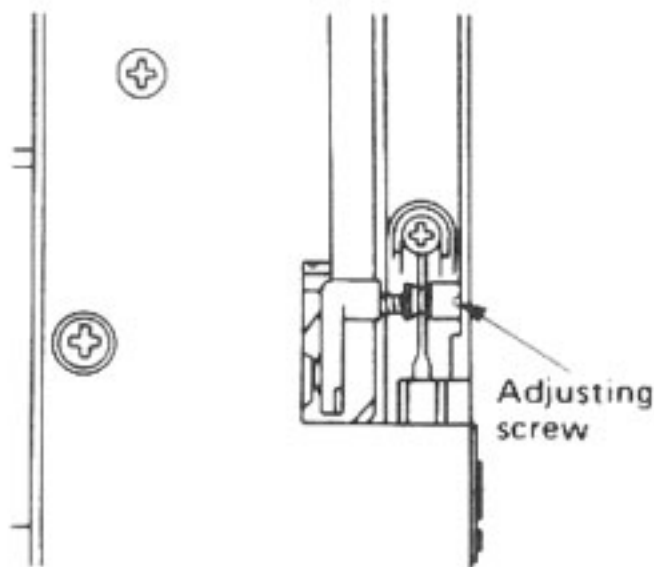

Fig. 24

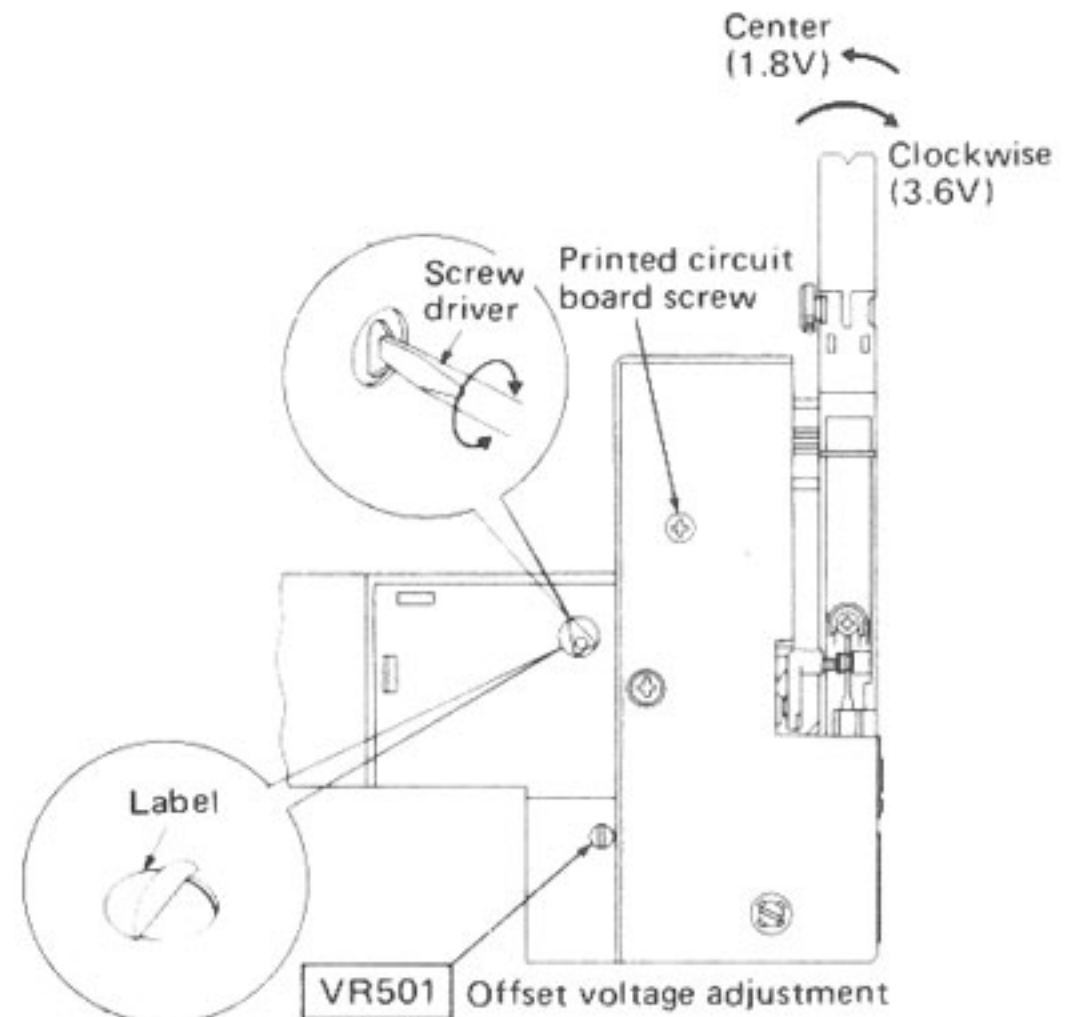

Fig. 25

## ■ TROUBLE SHOOTING

### 1. How to use the repair table (Fig. 26)

- ① Remove the bottom board.
- ② Remove the operation circuit board and connect the P.C.B. ground terminal to the chassis (Stator frame.)
- ③ Put the unit on the repair table.
- ④ Fit the turntable platter and put on the turntable mat.
- ⑤ Put on the record and check the circuits from under the unit.

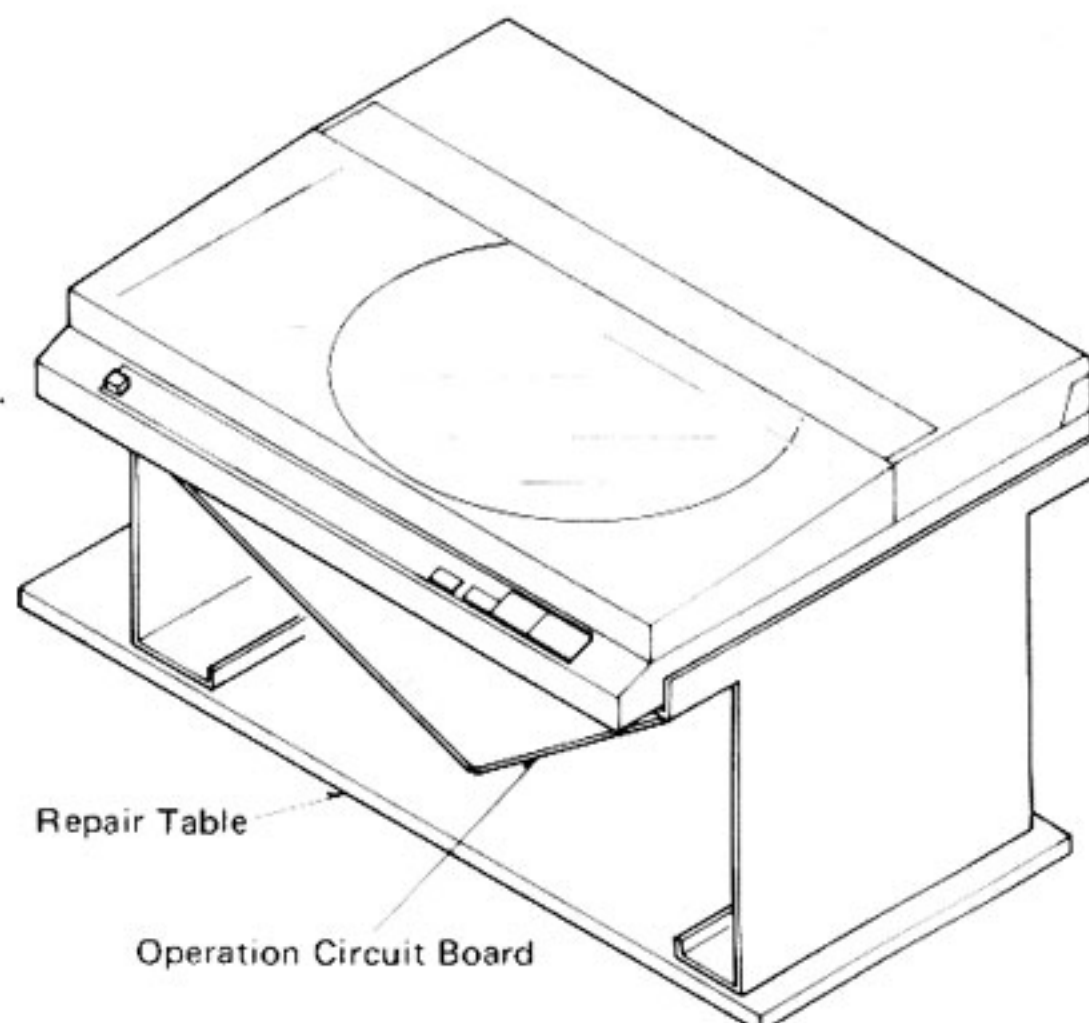

Fig. 26

### 2. How to raise the set (Fig. 27)

**Note:** Turntable platter is not fixed on the center spindle. Take care so that the turntable platter will not come loose. Also, take care allow the set to fall down.

- ① Remove the bottom board.
- ② Completely open the upper cabinet.
- ③ Hold the cabinet (Reset) switch with tape.
- ④ Fit the turntable platter.
- ⑤ Raise the unit and check the circuits.

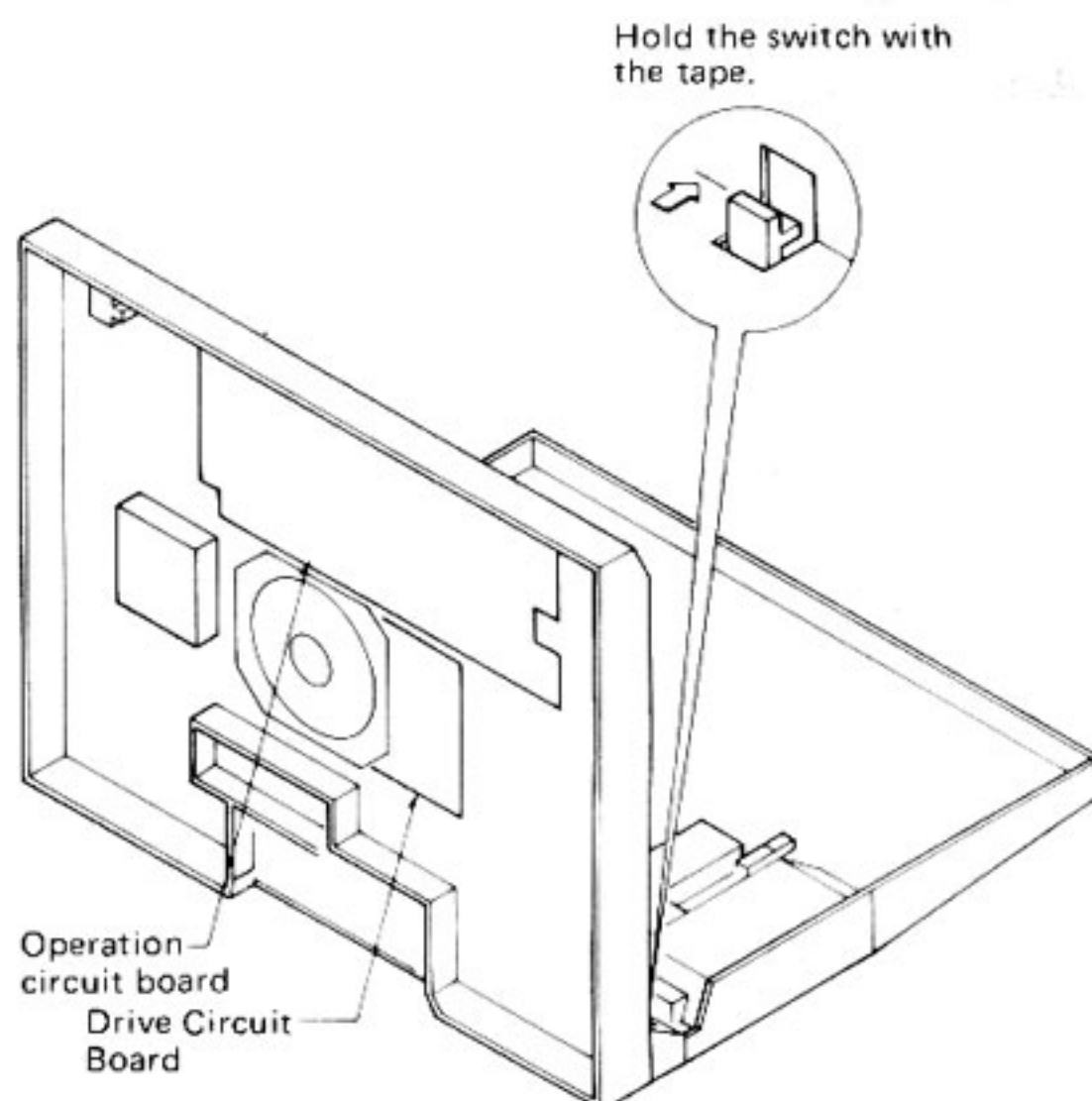

Fig. 27

### 3. How to turn over the set (Fig. 28)

**Note:** This purpose is to check the voltage of each circuit during stop of the turntable.

- ① Remove the turntable platter and turn over the unit.
- ② Remove the bottom board.
- ③ Turn the power switch "on" and check the voltage.

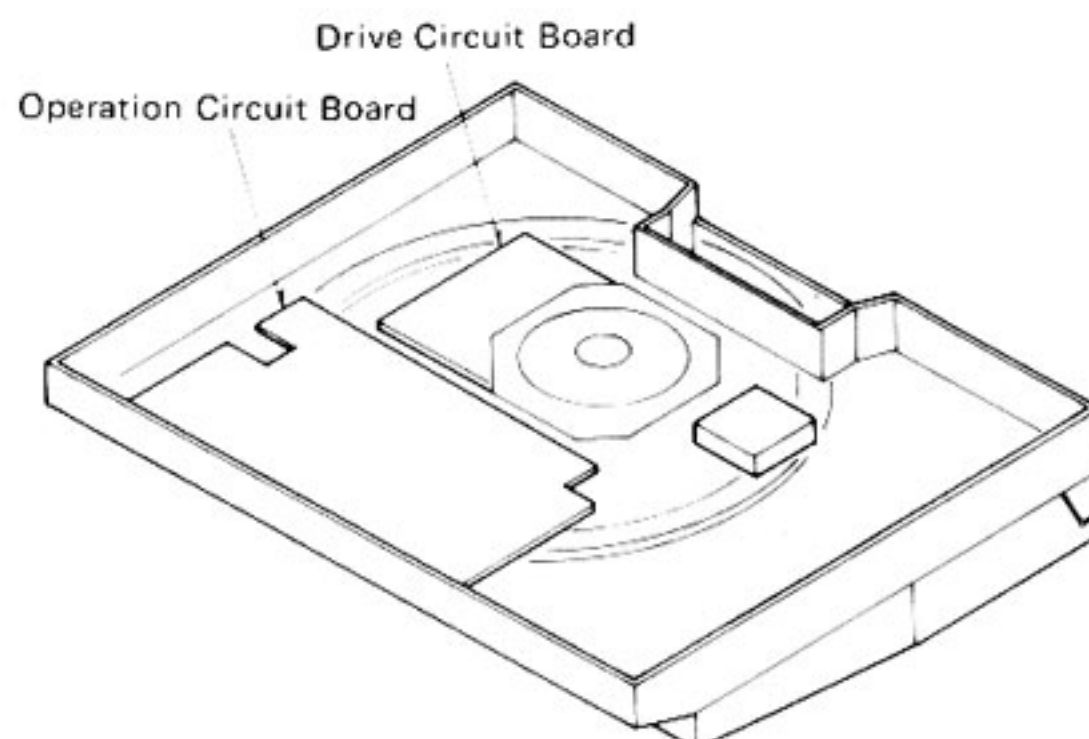
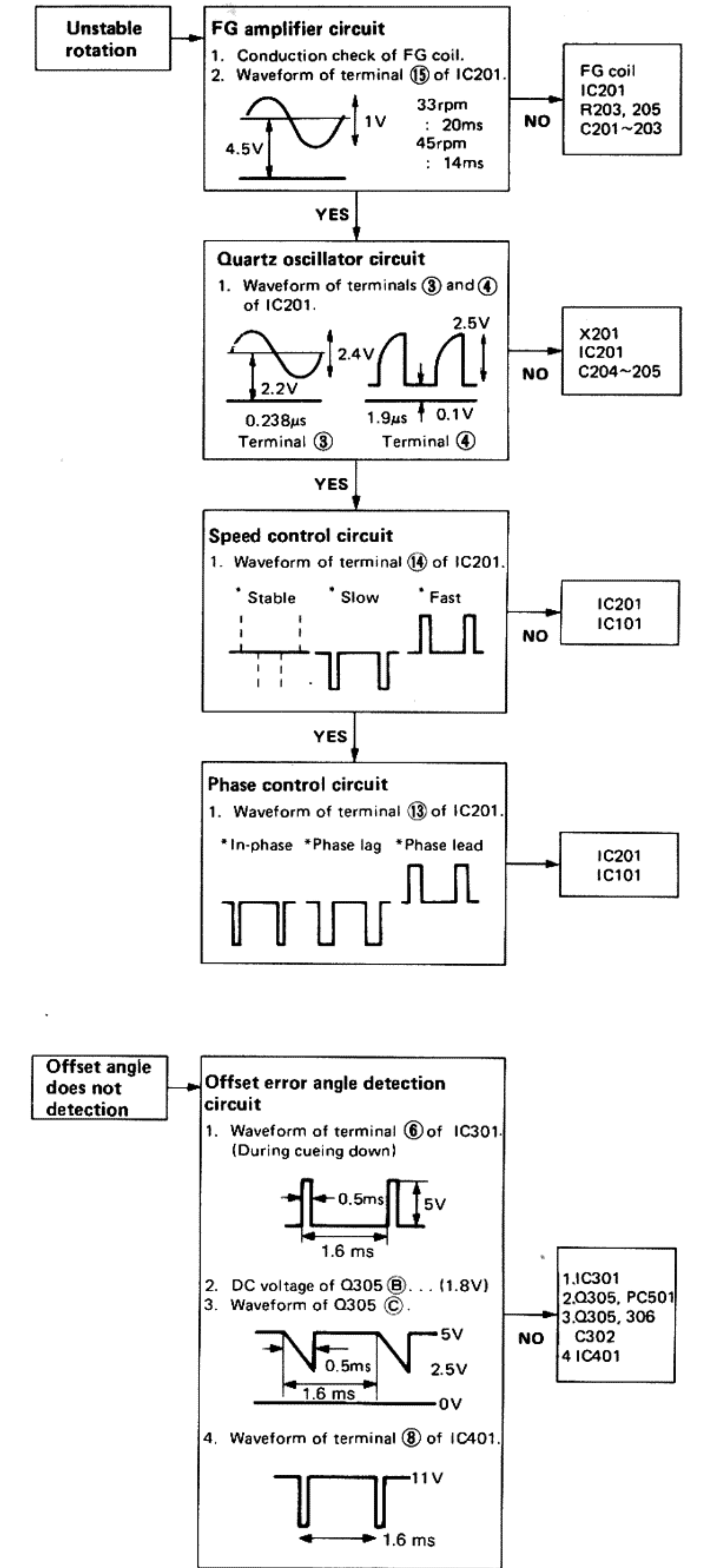
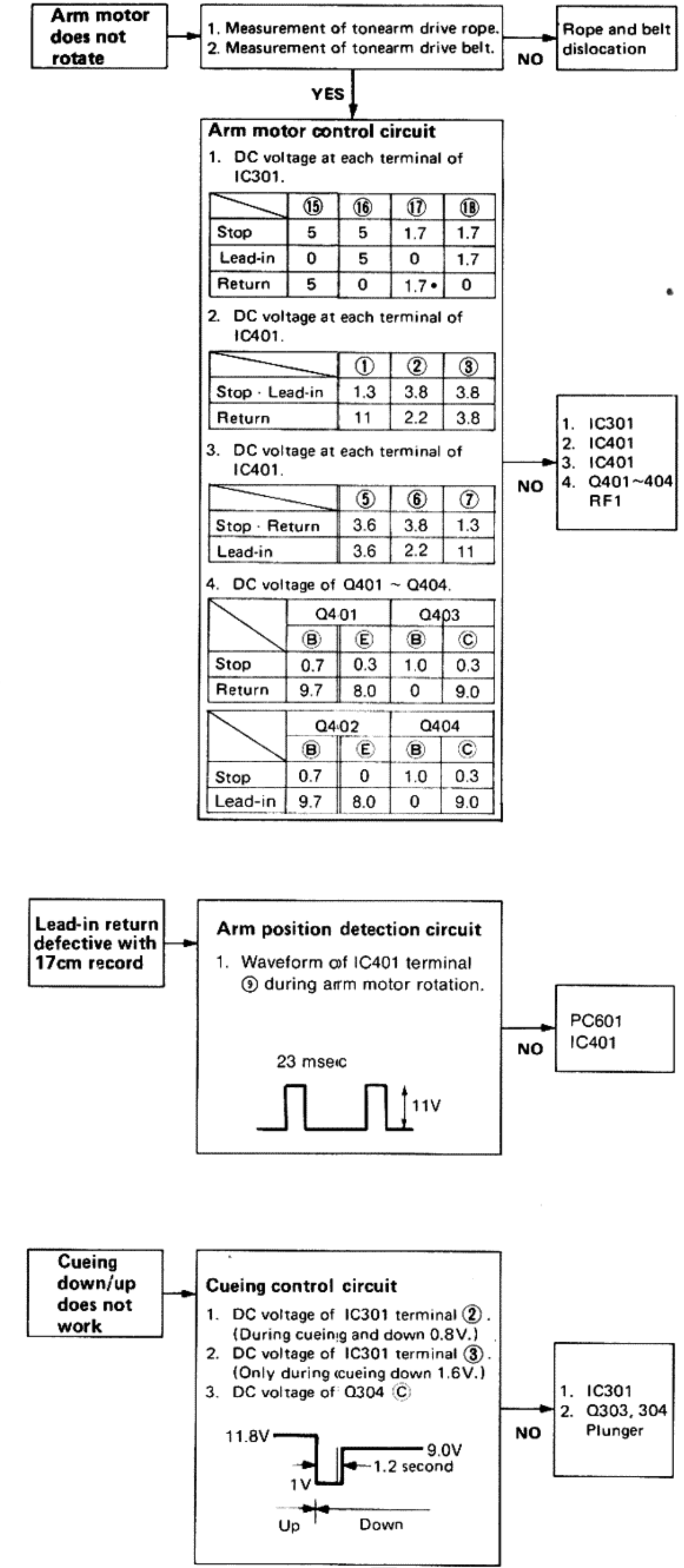
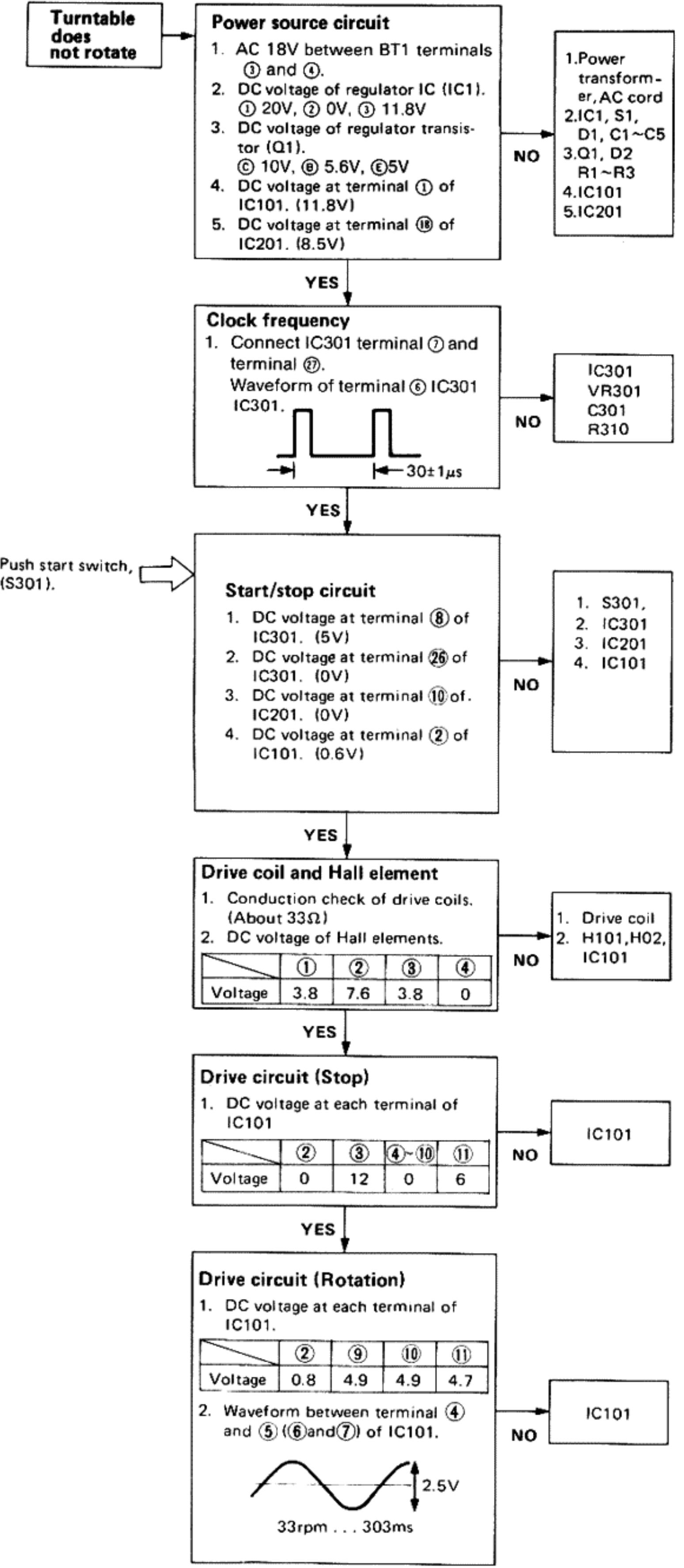

Fig. 28





## ■ FUNCTION OF TERMINAL (MN1421FPC)

\* These are the basic functions of MN1421FPC. Therefore, some terminals are not necessary of circuit functions may be partially changed depending on the purposes.

No.	Mark	Description	No.	Mark	Description
1	VSS	Ground terminal	14	Bi0	Record detection terminal ("H" when record is present)
2	CO9	Cueing control terminal ("H" during cueing and cueing down)	15	EO0	Tonearm drive motor control terminal (Arm servo)
3	CO8	Cueing control terminal ("H" only during cueing down — about 1 sec.)	16	EO1	
			17	EO2	
			18	EO3	
4	CO7	Key scan output terminal	19	TEST	Test terminal (not used, connected to ground)
5	CO6		20	RST	Reset terminal (micom is reset at "L")
6	CO5		21	SNS0	Offset angle detection input terminal
7	Ai3	Key scan input terminal	22	SNS1	Arm position detecting input terminal
8	Ai2		23	DO0	Turntable speed select terminal ("H" in 45rpm; "L" in 33rpm)
9	Ai1		24	DO1	Repeat indicator terminal (ON at "L")
10	Ai0		25	DO2	Synchro-rec on/off terminal
11	Bi3	Auto size and speed select terminal Terminal ⑪, ⑫ "L" → 30cm record · 33rpm ⑪ "L" ⑫ "H" pulse → 17 cm record · 45rpm	26	DO3	Turntable start/stop select terminal ("L" at start; "H" at stop)
12	Bi2		27	VDD	Power supply (+5V)
			28	OSC	Oscillation circuit (Clock frequency is adjusted to $30\mu\text{s} \pm 1\mu\text{s}$ )
13	Bi1	Rest position detecting terminal ("H" when tonearm is at rest position)			

## ■ RESISTORS AND CAPACITORS

- Notes:**
- Part numbers are indicated on most mechanical parts. Please use this part number for parts orders.
  - Important safety notice: Components identified by  $\Delta$  mark have special characteristics important for safety. When replacing any of these components use only manufacturer's specified parts.
  - This "(S)" mark is service standard parts and may differ from production parts.
  - Unless otherwise specified. All resistors are in OHMS ( $\Omega$ ) K = 1000 $\Omega$ , M = 1000k $\Omega$ . All capacitors are in MICROFARADS ( $\mu\text{F}$ ) P =  $10^{-6}$   $\mu\text{F}$ .

### Numbering System of Resistor

Example

ERD	25	F	J	101
Type	Wattage	Shape	Tolerance	Value
ERG	1	AN	J	2R2
Type	Wattage	Shape	Tolerance	Value

ERD2FCG□□□ → Fuse type carbon (1/4W)  
 ERD10TLJ□□□ → Chip type carbon (1/8W)  
 ECUV1H□□□ → Chip type ceramic

### Numbering System of Capacitor

Example

ECKD	1H	102	Z	F
Type	Voltage	Value	Tolerance	Peculiarity
ECEA	50	M	R47	R
Type	Voltage	Peculiarity use	Value	Special use

Resistor Type	Wattage	Tolerance
ERD : Carbon	25 : 1/4W	J : $\pm 5\%$
ERX : Metal Film	1 : 1W	G : $\pm 2\%$
ERTD : Thermister		

Capacitor Type	Voltage		Tolerance
	ECEA Type	Others	
ECEA : Electrolytic	1A : 10V	1H : 50V DC	J : $\pm 5\%$
ECEB : Electrolytic	1C : 16V	2H : 500V DC	K : $\pm 10\%$
ECKD : Ceramic	1E : 25V	1 : 100V	Z : +80%, -20%
ECQM : Polyester	1V : 35V		P : +100%, -0%
	1H : 50V		M : $\pm 20\%$
	50 : 50V		





Ref. No.	Part No.	Value
<b>CABINET AND CHASSIS PARTS</b>		
1	SFWE06N01	Adaptor, 45r.p.m (1)
2	SFQAC06N01	Spring, 45r.p.m. Adaptor (1)
3	SFTGQ05N01	Turntable Mat (1)
4	SFTEQ05N01	Turntable Platter (1)
5	SFTMC07-01E	Rotate Magnet Ass'y (1)
6 [M]	SFNNQL5M01	Name Plate (1)
6 [MC]	SFNNQL5C01	Name Plate (1)
7	SFATQ15N01A	Hinge (Right Side) (1)
8	SFATQ15N02A	Hinge (Left Side) (1)
9	SFKKQL5N02	Ornament Plate (1)
10	SFACQL5N01	Cabinet (1)
11	SFUMC05N15	Holder, Rest Switch and Record Detecting Switch (2)
12	SFQPC05N01	Spring, Reset Switch (1)
13	SFNZQL5M01	Label, Speed Select (1)
14	SFUMD05N03	Rod, Speed Select Switch (1)
15	SFKTQL5N01	Button, Operation (1)
16	SFKTD05N02	Knob, Speed Select (1)
17	SFMGQ34N01	Cover, Stator Coil (1)
18	SFMZC06N01R	Stator Frame Ass'y (1)
19	SFUMQL5N01E	Lever, Record Detecting (1)
20	SFUMQ15N03	Holder, L.E.D (1)
21	SFUPQL5N01	Holder, Operation Button (1)
22	SFAUL12M01	Bottom Board (1)
23	SFGAC05N02	Insulator (4)
24	SFOCC05N01	Spring, Insulator (4)
25	SFGCC05N02	Cushion Rubber, Power Transformer (2)
26	SFGZC05N03	Cushion rubber, Power Transformer (1)
27	SFKTO15N03	Knob, Power Switch (1)
28	SFXJBL3N02E	Shaft Ass'y Power Switch (1)
29	SFUMQ15N04	Stopper, Operation Circuit Board (1)
30	SFQABL3N02	Spring, Power Switch Shaft (1)
31	SFUMBL3N05	Holder, Power Switch Shaft (1)
32	SFADD05N01E	Dust Cover Ass'y (1)
32-1	SFAD130-02	Cushion Rubber, Dust Cover (2)
33	SFKKQL5N01	Record Groove Scale Plate (1)
34	SFGCC05N03	Rubber Spacer (3)
35	SFGCD05N01	Rubber Spacer (2)
36	SFGCC05N06	Rubber Spacer (2)
37	SFUZC05N03	Latch, Lead Wires Holder (1)
38	SFUMC05N20	Holder, Lead Wires (1)
39	SFUKD05N01A	Base, Tonearm (1)
40	SFUMC05N17	Wheel, Tonearm Drive (1)
41	SFUMC05N02A	Rest Switch Ass'y (1)
42	SFUMQL5N02A	Worm Gear Ass'y (1)
43	SFGB10-01	Belt, Tonearm Drive Motor (1)
44	SFMHC05N01E	Tonearm Drive Motor Ass'y (1)
45	SFUZC05N01	Rod, Rest Switch (1)
46	SFXJC05N01	Guide Rail, Tonearm (1)
47	SFGCC05N05	Cushion Rubber, Guide Rail (2)
48	SFUPC05N03	Bracket, Guide Rail (1)
49	SFUMD05N02	Cover, Tonearm Base (B) (1)
50	SFUMD05N01	Cover, Tonearm Base (A) (1)
51	SFUZC05N02E	Rope Ass'y (1)
52	SFUMC06N11	Cap, Pulley (3)
53	SFUMC05N22	Pulley, Rope Ass'y (3)
54	SFDJHSC0491	AC Socket (1)
55	SFDHC05N02E	Phono Output Jack Ass'y (1)
56	SFUMQ05N02A	Record Size Detector Ass'y (1)
57	SFUMC05N11A	Record Detector Ass'y (1)
58	SFUMC05N06	Guide, Rest Switch Rod (1)
<b>ONEARM PARTS</b>		
71	SFPAM00501A	Tonearm Ass'y (1)
74	SFPSP00503	Spring, Lead Wire (1)
75	SFPGM00502	Holder, Phono Output Cord (1)
76	SFPAB00502	Bracket, Tonearm (1)
77	SFPGM00503	Rubber Spacer (1)
78	SFPAB00501E	Tonearm Position Indicator Ass'y (1)
78-1	SFPGM00505	Holder, L.E.D Circuit Board (1)
79	SFPZB00503E	Lift Solenoid Ass'y (1)
80	SFPCS00501	Cover, Tonearm Base (1)

Ref. No.	Part No.	Value
<b>SCREWS, WASHERS AND NUT</b>		
N1	XTV3+10BFN	Screw, ① 3×10 (20)
N2	XTN3+6BFZ	Screw, ② 3×6 (3)
N3	XTN3+5J	Screw, ③ 3×5 (3)
N4	XTW3+10Q	Screw, ④ 3×10 (1)
N5	XTV3+20BFN	Screw, ⑤ 3×20 (5)
N6	XTV3+20BFZ	Screw, ⑥ 3×20 (2)
N7	SFXGD05N01	Screw (2)
N8	XTV3+8BFN	Screw, ⑦ 3×8 (1)
N9	SFXGC05N02	Screw (3)
N10	SFXGC05N03	Screw (2)
N11	XTW3+14QFYR	Screw, ⑧ 3×14 (6)
N12	XTV3+6BFN	Screw, ⑨ 3×6 (4)
N13	XWC3B	Washer (1)
N14	XUB3FP	Washer (1)
N15	SFXW551D2	Washer (1)
N16	SFGCC05N04	Washer (3)
N17	SFGCD05N02	Washer (2)
N18	SFXWC05N07	Washer (3)
N19	SFXWC06N02	Washer (1)
N20	XNC3HS	Nut (5)
N21	SFPEV00502	Screw, Cartridge (1)
N22	XSN3+12S	Screw, ⑩ 3×12 (1)
N23	XTN3+8BFZ	Screw, ⑪ 3×8 (2)
N24	XTN26+6BFZ	Screw, ⑫ 2.6×6 (1)
N25	XTW26+6JFZ	Screw (2)
N26	XTV3+10BFZ	Screw (1)
N27	XTN2+6JFZ	Screw (1)
N28	XTN2+4JFZ	Screw (1)
N29	XWA3B	Washer, φ3 (1)
N30	XWG3	Washer, φ3 (1)
N31	XWC26AFY	Washer, φ2.6 (1)
N32	SFPEW00701	Washer (1)

Ref. No.	Part No.	Value
<b>ACCESSORIES</b>		
A1 [M]	SFNUQL5M01	Instruction Book (1)
A1 [MC]	SFNUQL5C01E	Instruction Book (1)
A2	SFDHC05N01	Phono Output Cord (1)
A3	SFDLC05N01	Ground Wire (1)
A4	SFDAC05M01	AC Cord (1)
<b>PACKING PARTS</b>		
P1 [M]	SFHPQL5M01	Carton Box (1)
P1 [MC]	SFHPQL5C01	Carton Box (1)
P2	SFHHL13R01	Pad, Front (1)
P3	SFHHL13R02	Pad, Rear (1)
P4	SFHKC05N01	Clamper, Turntable (3)
P5	SFHKC05N02	Spacer, Tonearm (1)
P6	SFHSL13R01	Spacer, Dust Cover (1)
P7	SFHDQ06N01	Pad, Turntable Mat (1)
P8	SFYF33B35	Polyethylene Bag, Turntable Mat (1)
P9	SFYH60×60	Polyethylene Bag, Unit (1)
P10	SFYH18×17	Polyethylene Bag, Accessories (1)

## EXPLODED VIEWS

### • Tonearm Parts

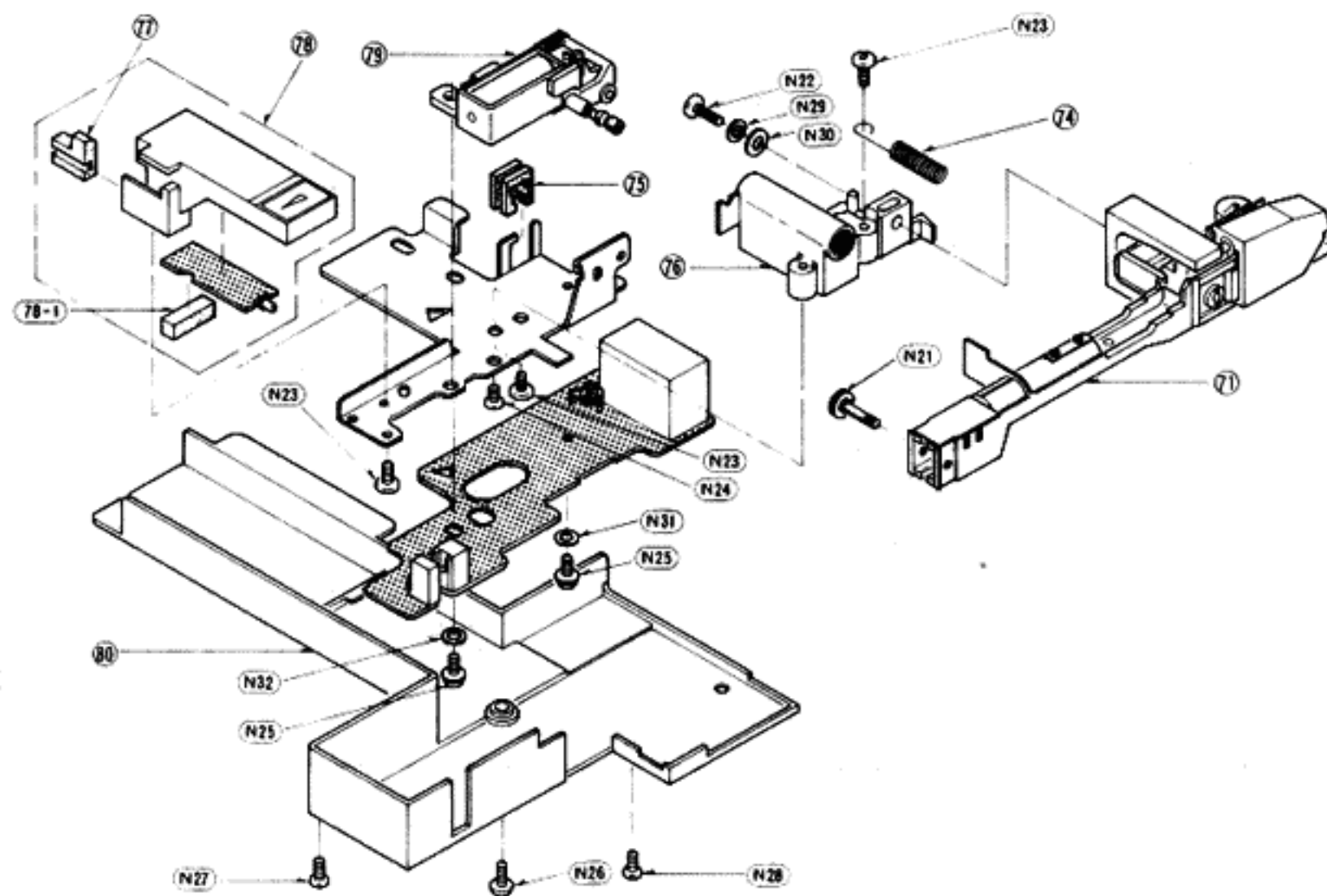





# ■ CIRCUIT BOARD AND WIRING CONNECTION DIAGRAM

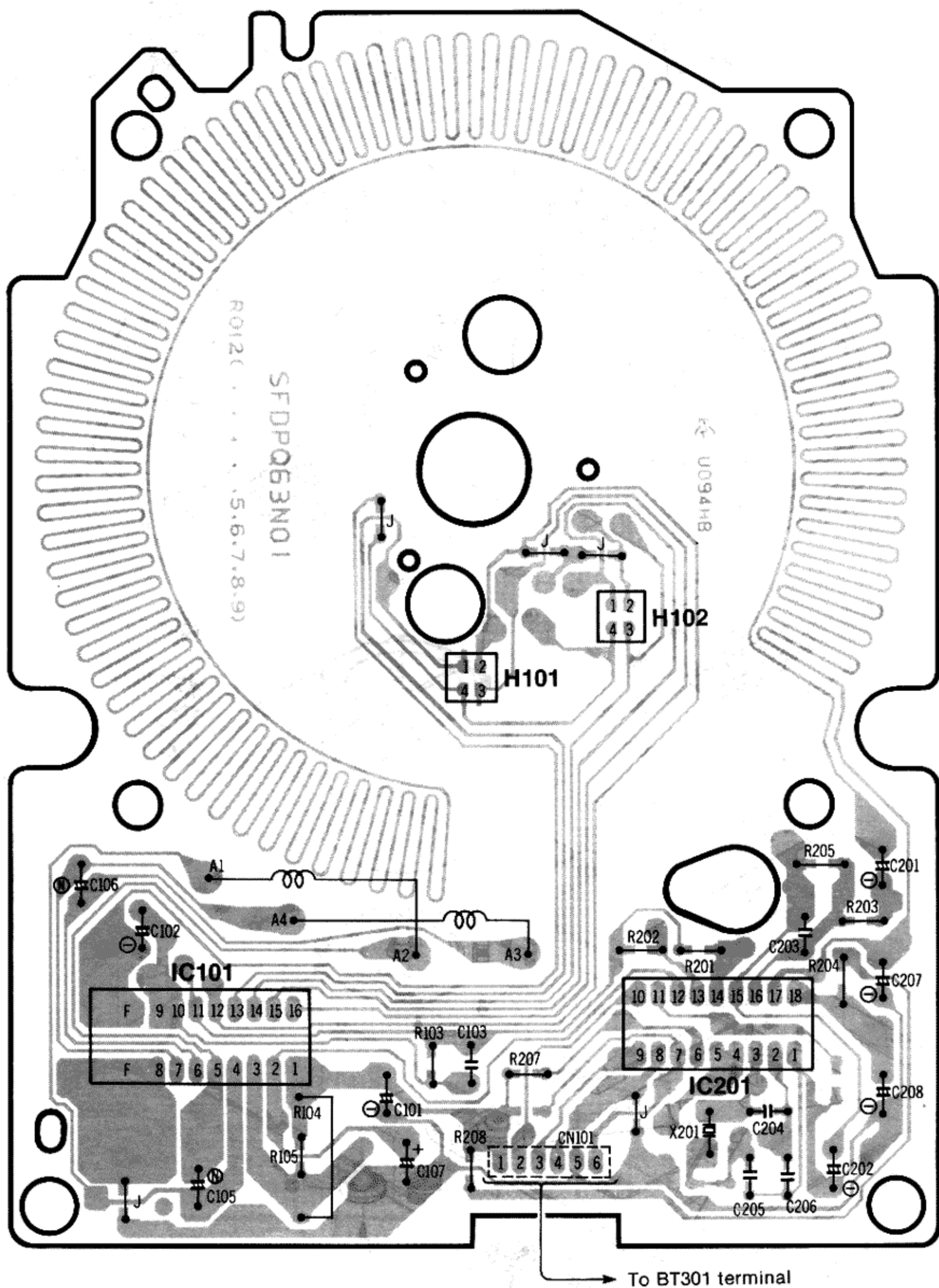



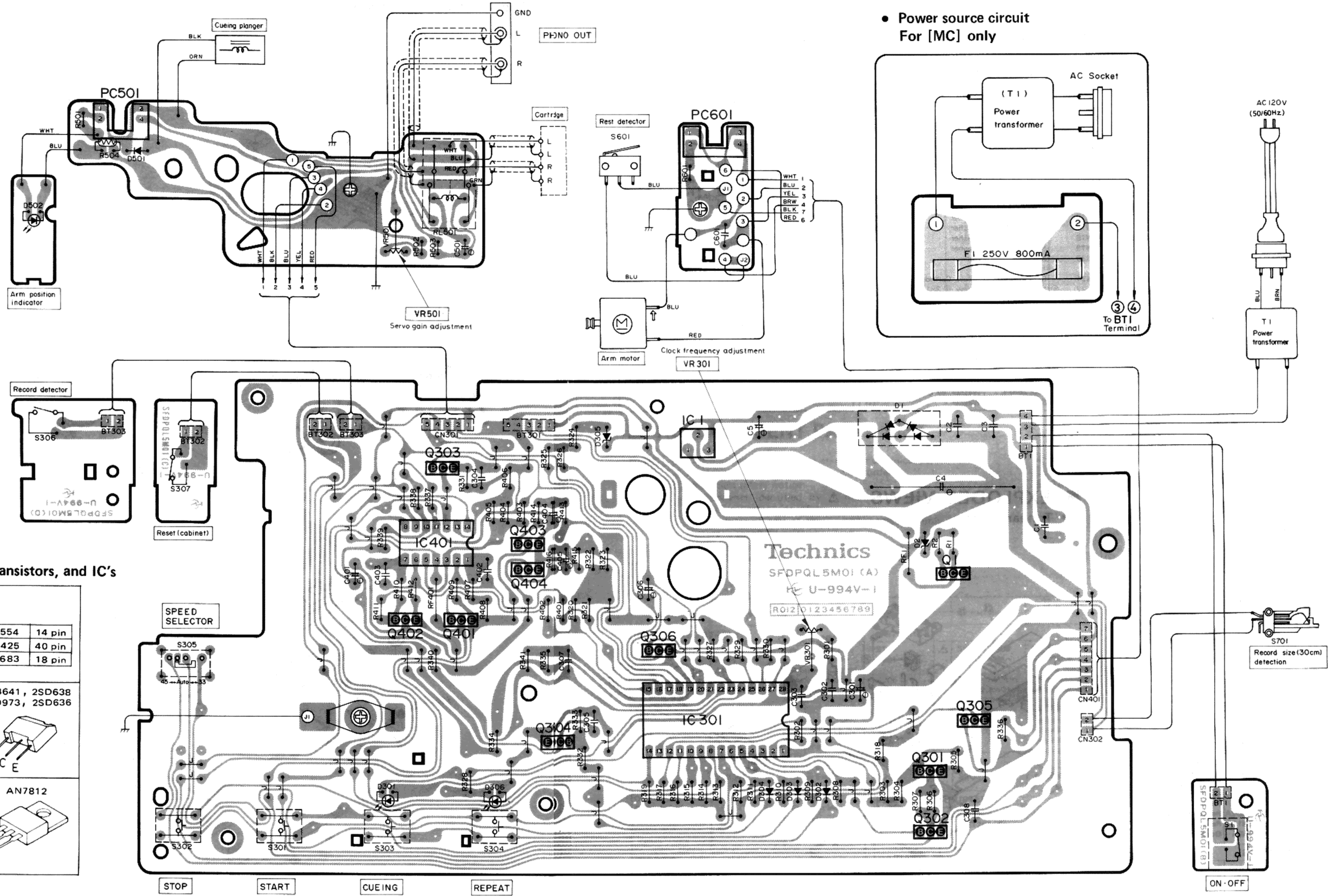

• Power source circuit  
For [MC] only

• Terminal guide of transistors, and IC's

	AN6554 14 pin
	MN1425 40 pin
	AN6683 18 pin
	2SB641, 2SD638 2SD973, 2SD636
	2SD892
	AN7812







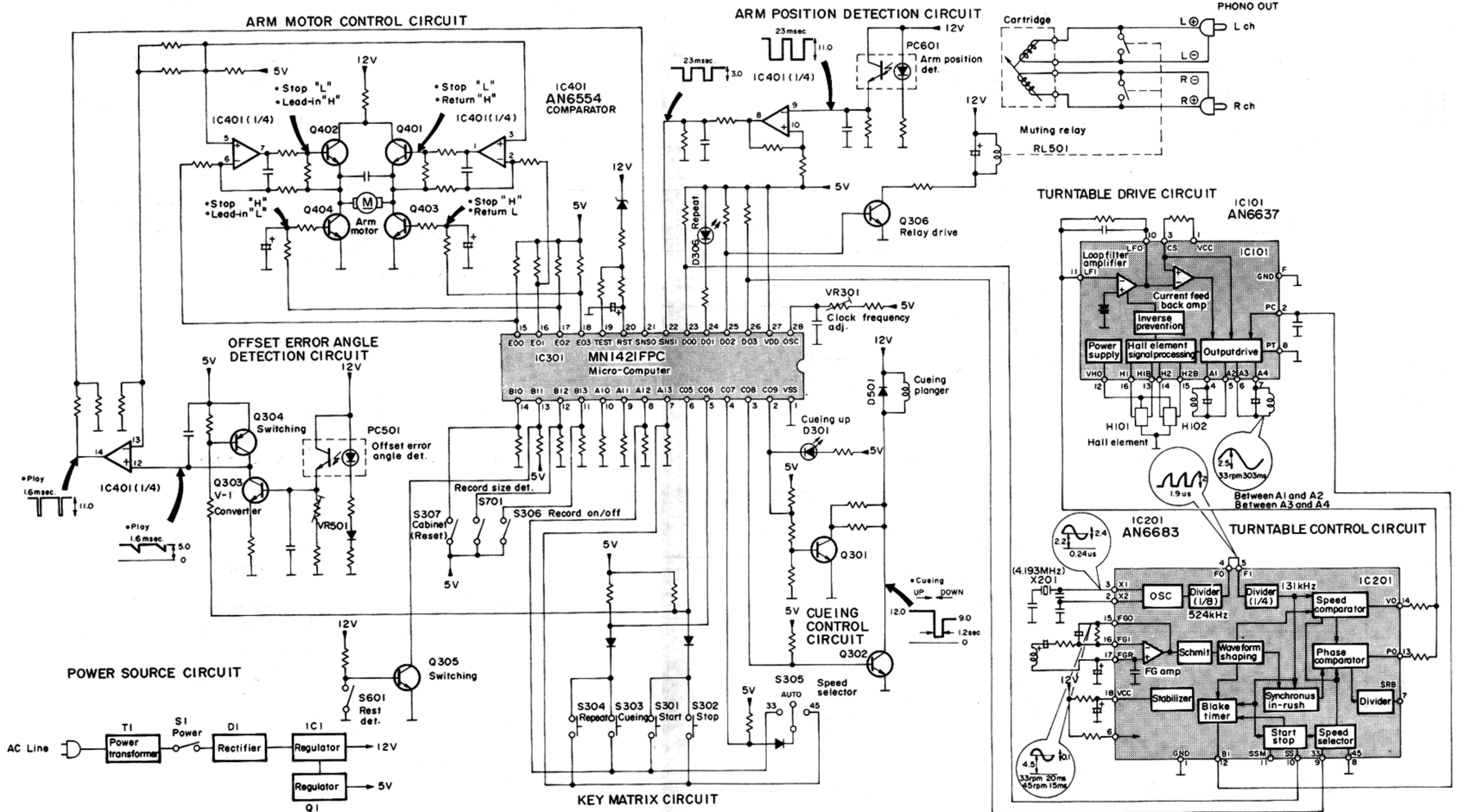



# PACKING

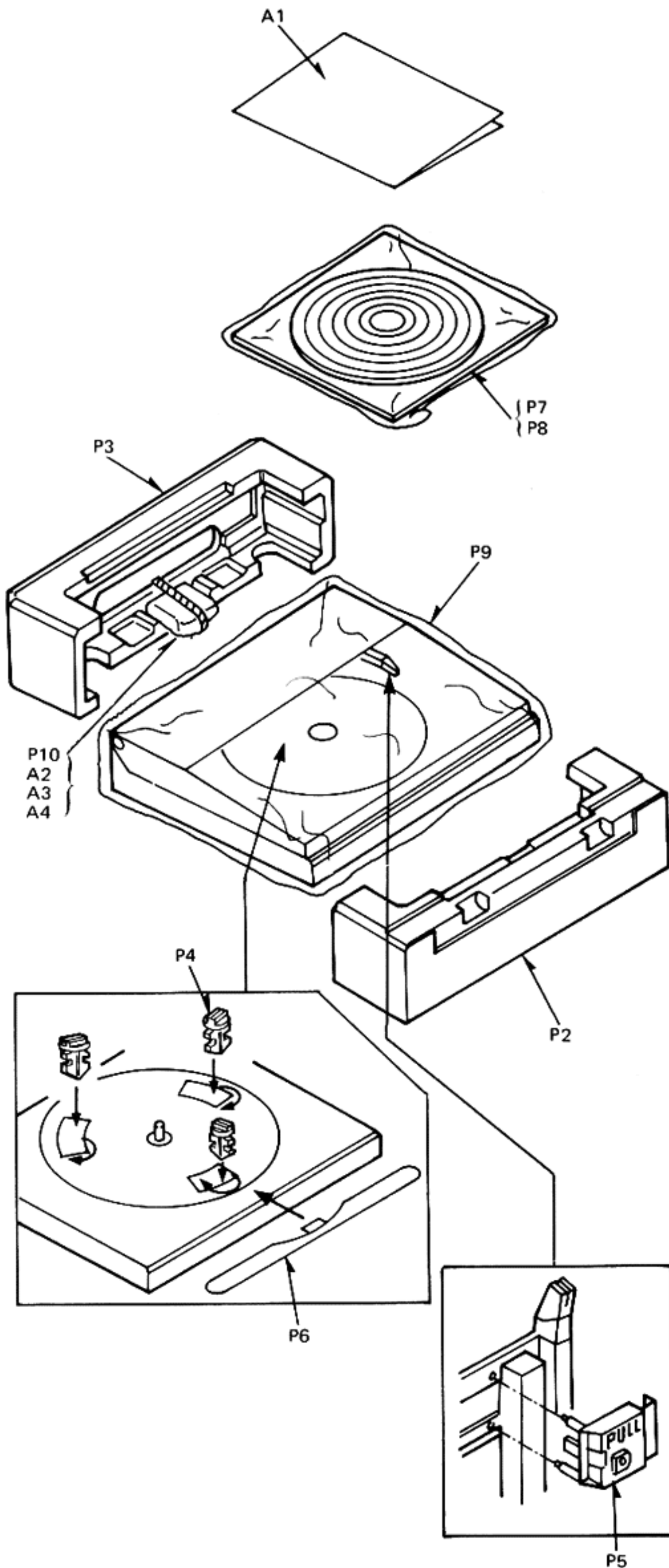

1. Place the unit (with cushions attached) as illustrated.
2. Fold the flaps according to the line marks.
3. Seal the top with adhesive tape.
  - \* Use gum tape or adhesive cloth tape of 50mm wide at least.
4. For the edges, first fold the flap "a" and then flap "b", and staple. Remember to staple only flap "b". (Use 15 or 16mm staple)

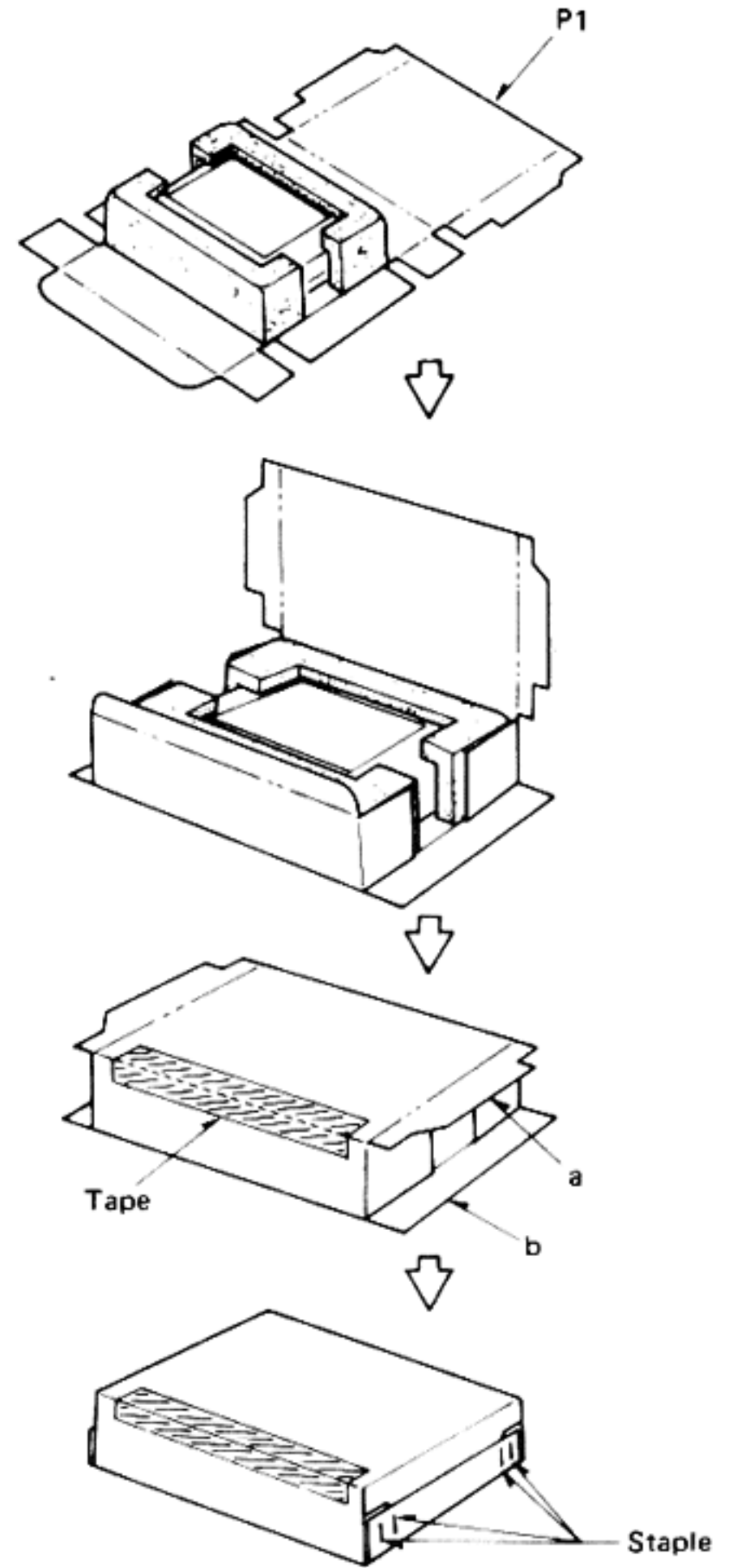

\* Stapling positions are shown below.

