

Total solder points: 220+ 65
Difficulty level:
beginner 1 2 3 4 5 *advanced*

Passive Preamp with RF remote control

K8022

- Two stereo line level RCA inputs**
- One stereo RCA output to power amp**
- Motor controlled volume control**
- RF remote control for all functions.**
- The remote does not need to 'see' the receiver**
- Self-learning code**
- Range : up to 15m/yards depending on environment.**
- Manual operation possible**
- Gold plated RCA connectors**
- Relay controlled input section**
- Totally passive**

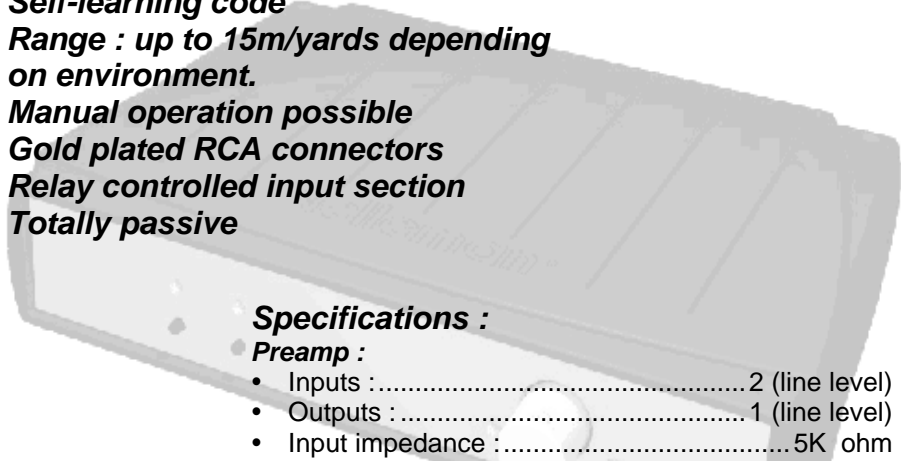

Specifications :

Preamp :

- Inputs : 2 (line level)
- Outputs : 1 (line level)
- Input impedance : 5K ohm
- Output impedance : 2.5K ohm
- Volume control speed : .15s typ. (0 to max. volume)
- Dimensions : 235x165x47mm (9,5" x 6,7" x 1,9")
- Power supply : 12VDC / 300mA



Remote Control :

- 433MHz operation
- Approved design (report BLC/96-0452 according to I-ETS 300 220)
- Keychain-style
- Battery (not included) :12V type V23GA, GP23A, ...
- Dimensions : 39x15x57mm (1,57" x 0,6" x 2,3")

1. Assembly (Skipping this can lead to troubles !)

Ok, so we have your attention. These hints will help you to make this project successful. Read them carefully.

1.1 Make sure you have the right tools:

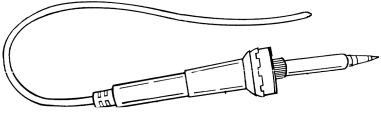
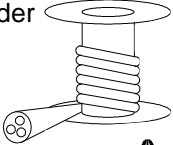
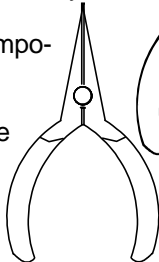
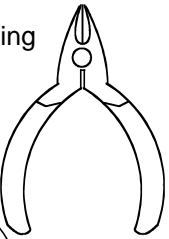
- A good quality soldering iron (25-40W) with a small tip. 
- Wipe it often on a wet sponge or cloth, to keep it clean; then apply solder to the tip, to give it a wet look. This is called 'thinning' and will protect the tip, and enables you to make good connections. When solder rolls off the tip, it needs cleaning. 
- Thin raisin-core solder. Do not use any flux or grease.
- A diagonal cutter to trim excess wires. To avoid injury when cutting excess leads, hold the lead so they cannot fly towards the eyes.
- Needle nose pliers, for bending leads, or to hold components in place. 
- Small blade and phillips screwdrivers. A basic range is fine. 



For some projects, a basic multi-meter is required, or might be handy

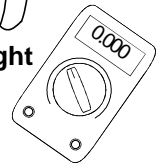

1.2 Assembly Hints :

- ⇒ Make sure the skill level matches your experience, to avoid disappointments.
- ⇒ Follow the instructions carefully. Read and understand the entire step before you perform each operation.
- ⇒ Perform the assembly in the correct order as stated in this manual
- ⇒ Position all parts on the PCB (Printed Circuit Board) as shown on the drawings.
- ⇒ Values on the circuit diagram are subject to changes.
- ⇒ Values in this assembly guide are correct*
- ⇒ Use the check-boxes to mark your progress.
- ⇒ Please read the included information on safety and customer service

* Typographical inaccuracies excluded. Always look for possible last minute manual updates, indicated as 'NOTE' on a separate leaflet.

1.3 Soldering Hints :

1- Mount the component against the PCB surface and carefully solder the leads

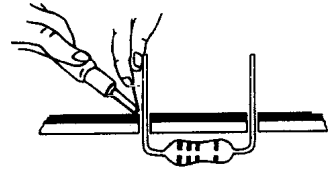

2- Make sure the solder joints are cone-shaped and shiny

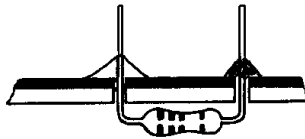
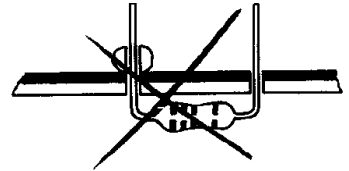

3- Trim excess leads as close as possible to the solder joint

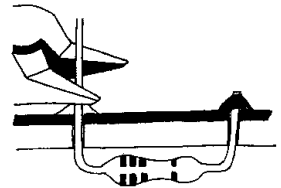

AXIAL COMPONENTS ARE TAPED IN THE CORRECT MOUNTING SEQUENCE !

REMOVE THEM FROM THE TAPE ONE AT A TIME !

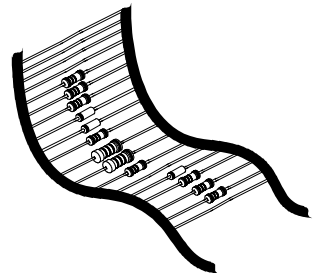

Velleman hereby certifies that the device K8022 meets the essential requirements and all other relevant stipulations of directive 1999/5/EG and 1995/5/EC.

For the complete conformity declaration check out : http://www.velleman.be/downloads/doC/CE_K8022.pdf

COLOR = 2 ... :

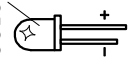

1%

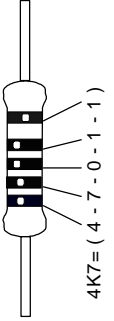

5%

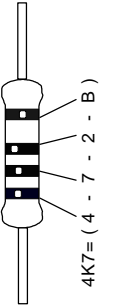

C O D E	I	P	E	S F	S	D K	N	D	G B	F	N L
C O D I C E C O L O R E	C O D I G O D E C O R E S	C O D I G O D E C O L O R E S	V Á R I K O O D I	F Á R G S C H E M A	F A R V E - K O D E	F A R G E - K O D E	F A R B K O D E	C O U L O U R C O D E	C O U L O U R C O D E	K L E U R C K O D E	K L E U R C K O D E
0	Nero	Negro	Musta	Svart	Sort	Sort	Schwarz	Black	Noir	Zwart	Zwart 0
1	Marrone	Marrón	Ruskea	Brun	Brun	Brun	Braun	Brown	Brun	Bruin	Bruin 1
2	Rosso	Rojo	Punainen	Röd	Röd	Röd	Rot	Red	Rouge	Rood	Rood 2
3	Aran- ciato	Naran- jado	Oranssi	Orange	Orange	Orange	Orange	Orange	Orange	Oranje	Oranje 3
4	Giallo	Amarillo	Keltainen	Gul	Gul	Gul	Gelb	Yellow	Jaune	Geel	Geel 4
5	Verde	Verde	Vihreä	Grön	Grøn	Grønn	Grün	Green	Vert	Groen	Groen 5
6	Blu	Azul	Sininen	Blå	Blå	Blå	Blau	Blue	Bleu	Blauw	Blauw 6
7	Viola	Morado	Purppura	Lila	Violet	Violet	Violet	Purple	Violet	Paars	Paars 7
8	Grigio	Cinzeno	Gris	Harmaa	Grå	Grå	Grau	Grey	Gris	Grijs	Grijs 8
9	Bianco	Blanco	Valkoinen	Vit	Hvidt	Hvidt	Weiss	White	Blanc	Wit	Wit 9
A	Argento	Plateado	Hopea	Silver	Sølv	Sølv	Silber	Silver	Argent	Zilver	Zilver A
B	Oro	Dourado	Oro	Kulta	Guld	Guld	Gold	Gold	Or	Goud	Goud B

IMPORTANT

The construction of this kit consists of two parts :

- The assembly of the passive preamp.
- The assembly of the RF remote control unit.

This manual only deals with the assembly and testing of the passive preamp.

Please refer to the supplied RF remote control manuals for details on the assembly and configuration of the RF remote control unit.

1. Jumperwires

- J1
- J2

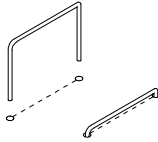

2. Resistors (check the color code)

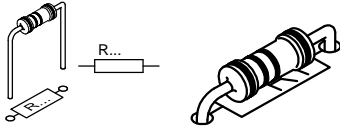

- R1: 10 (1-0-0)
- R2: 1K (1-0-2)
- R3: 1K (1-0-2)
- R4: 1K (1-0-2)
- R5: 10K (1-0-3)
- R6: 10K (1-0-3)
- R7: 10K (1-0-3)
- R8: 10K (1-0-3)
- R9: 270 (2-7-1)
- R10: 18K (1-8-3)
- R11: 33K (3-3-3)
- R12: 5K6 (5-6-2)
- R13: 2K7 (2-7-2)
- R14: 18K (1-8-3)
- R15: 6K8 (6-8-2)
- R16: 6M8 (6-8-5)
- R17: 1K (1-0-2)
- R18: 1K (1-0-2)
- R19: 2K2 (2-2-2)
- R20: 10K (1-0-3)
- R21: 1 (1-0-B)
- R22: 470 (4-7-1)

3. DIODES (Check the polarity)

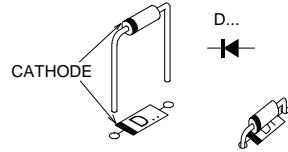

- D1 : 1N4007
- D2 : 1N4007
- D3 : 1N4007
- D4 : 1N4007
- D5 : 1N4007
- D6 : 1N4007
- D7 : 1N4148

4. Zener diodes (Check the polarity)

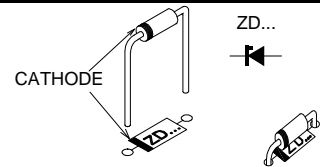

- ZD1 : 4V3
- ZD2 : 5V1

5. Axial coil

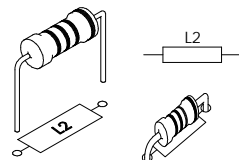

- L2 : 1µH (1-0-B)

6. IC socket (Watch the position of the notch)

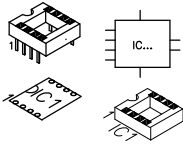

- IC1 : 8p
- IC2 : 8p

7. Capacitors

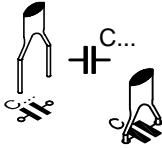

- C2 : 100n (104)
- C3 : 100n (104)
- C5 : 100n (104)
- C6 : 100n (104)
- C9 : 100n (104)
- C10 : 100n (104)
- C11 : 82p (82)
- C12 : 22p (22)
- C13 : 330p (331)
- C14 : 1p (1)
- C15 : 3p3 (3.3)
- C16 : 330p (331)
- C17 : 2p2 (2.2)

8. Transistors

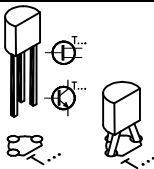

- T1 : BC547C
- T2 : BC547C
- T3 : **BC557C**
- T4 : **BC557C**
- T5 : BF199
- T6 : BC547C

9. Push buttons. Mount them straight against the PCB surface !

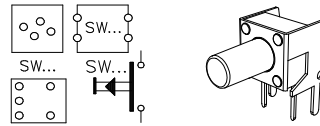

- SW1: TS-04PV
- SW2: TS-04PV

10. Adaptor jack. Mount it straight against the PCB surface !

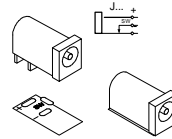

- SK1 : DJ-005

11. RCA connectors. Mount them straight and against the PCB

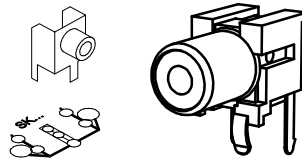

- SK2: MJ-523AG/B **BLACK**
- SK3: MJ-523AG/R **RED**
- SK4: MJ-523AG/B **BLACK**
- SK5: MJ-523AG/R **RED**
- SK6: MJ-523AG/B **BLACK**
- SK7: MJ-523AG/R **RED**

12. Tuning coil

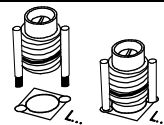

- L1 : MC1.5T

13. Relay

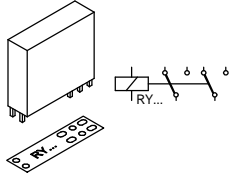

RY1 : VR1D122C

14. Electrolytic capacitors (Watch the polarity !)

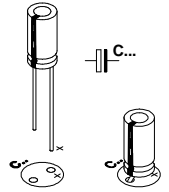

C1 : 1000 μ / 25V
 C4 : 470 μ / 25V
 C7 : 1000 μ / 25V
 C8 : 470 μ / 25V
 C18 : 1 μ / 50V

15. Voltage regulators

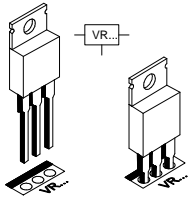

VR1 : 7809
 VR2 : 7806

**16. Potentiometer. Mount it straight and against the PCB
Connect as shown**

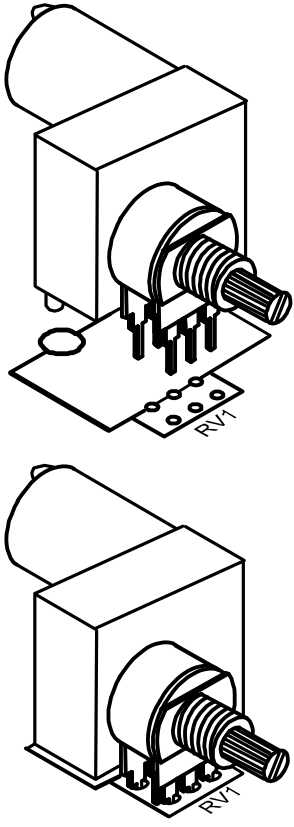

RV1

Connect the motor to the PCB by means of two wire jumpers

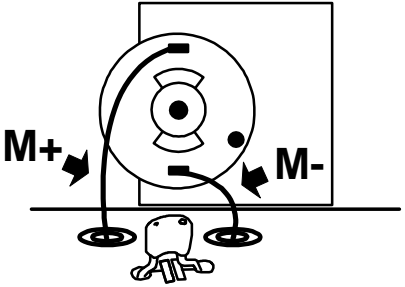

17. Mounting the LED's. Check the polarity ! Short lead = Cathode or - !

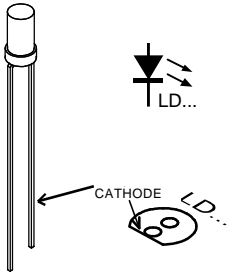

IMPORTANT

Mount these LED's exactly like in the drawing, otherwise some LED's will not fit correctly in the front panel.
Please also use the front panel as a positioning reference.

First: Bend the leads exactly like the drawing.

Next: Solder **one** lead, and check the position, if necessary correct by heating the soldering.

Last: Solder the second connection.

- LD1
- LD2

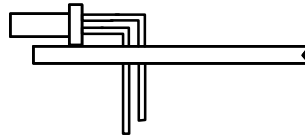
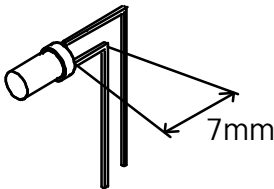

- LD3
- LD4

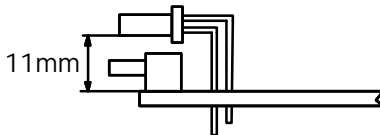
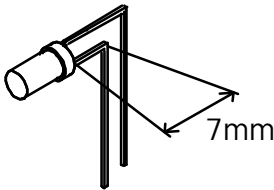

- LD5

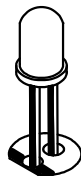
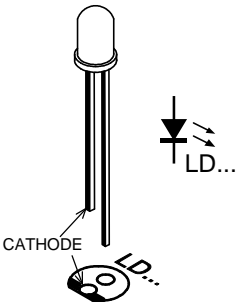

18. IC's
(Watch the position of the notch !)

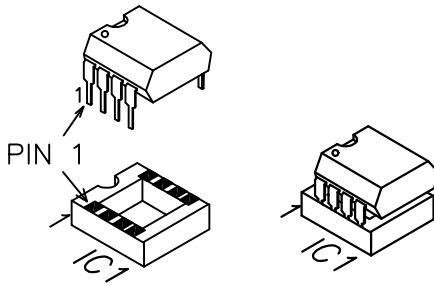

IC1 : VK8022
 (programmed PIC 12CE518)

IC2 : LM258 or eq.

19. Mounting the PCB into the enclosure

Make sure to remove the protective foil from the front and rear panel !
 Stick the supplied rubber feet onto the bottom of the enclosure.

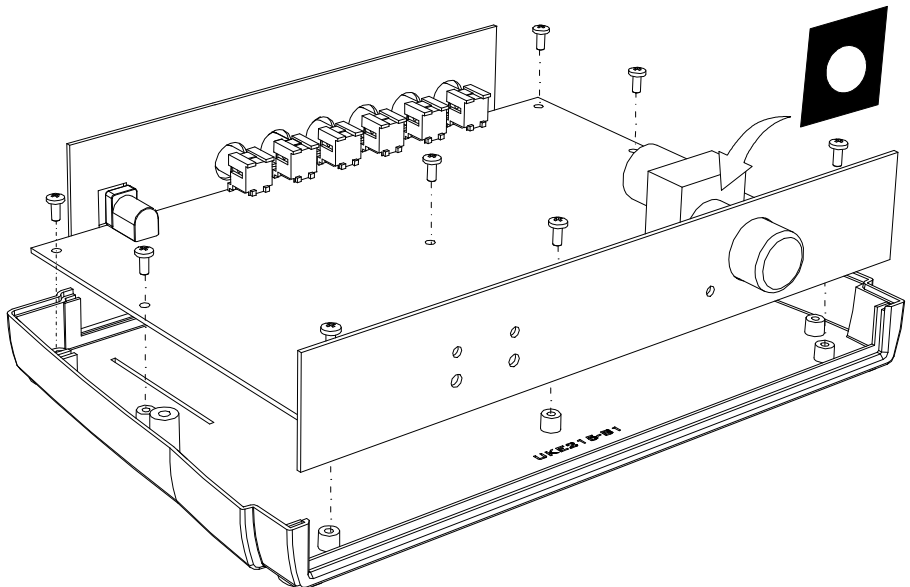

20. Adjustment and testing

Inspect the complete assembly once more before applying power to the unit !

An adaptor jack allows hook-up of a suitable 12VDC / 300mA wall adaptor. Make sure the input voltage matches your domestic AC voltage. Mind the polarity !

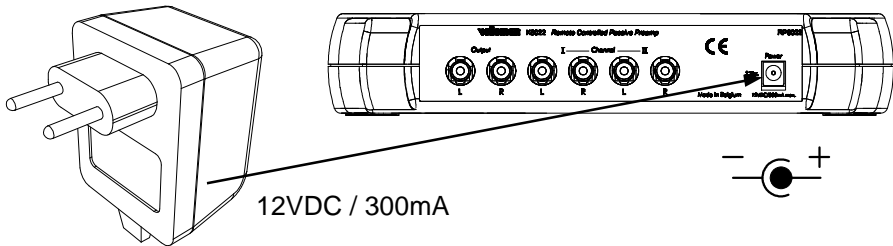

Plug the adaptor into a wall outlet. The left channel indicator lights and the volume control automatically turns to zero. The 'volume down'-led will also light until the volume control has reached it's endpoint. Press any button to stop this action.

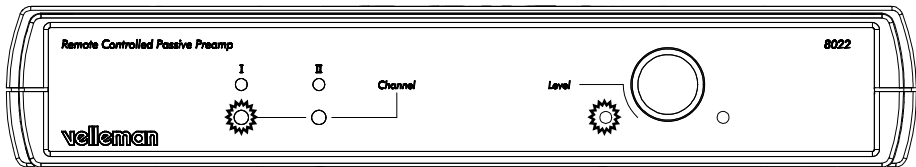

Now you can perform the adjustment of the RF receiver section. Use the supplied plastic screwdriver to adjust the tuning coil L1. Press and hold any button on the remote control and slowly adjust L1 until LD5 lights with maximum brightness. Next, call on some assistance and have somebody push the remote at a distance of a couple of meters/yards, while you slowly adjust L1 again for maximum brightness of LD5.

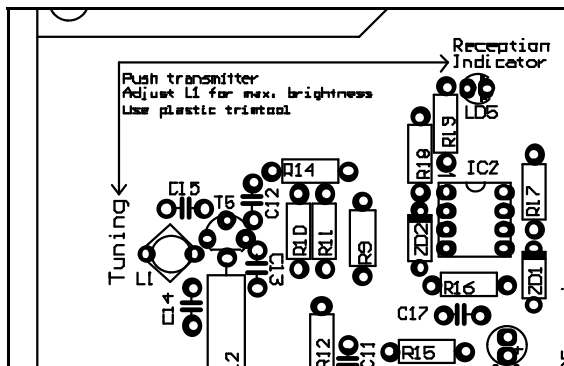

Adjustment and testing (continued)

Your K8022 is capable of grabbing and memorising the code transmitted from the Velleman two channel RF remote control transmitter.

At the factory, the K8022 processor has been pre-programmed for operation without a custom code (i.e. no jumpers on remote). There is no need to enter the learn-mode if no code has been set on your remote control. Should you experience interference due to other Velleman remotes with identical code settings, then you can set a different code on your remote control (see remote control manual for 'how-to' instructions). Once the transmitter code is set, the K8022 will need to learn and memorise it.

How to operate the learn-mode:

- Press and hold SW1 (Channel 1) and plug-in power supply.
- Release SW1

- LD2 will turn on briefly.
- Press 'volume down' (left button) on remote.
- LD2 will turn on briefly to confirm.
- Release 'volume down'

- LD1 will turn on briefly
- Press 'volume up' (right button) on remote.
- LD1 will turn on briefly to confirm.
- Release 'volume up'

- Channel indication (LD3&LD4) will toggle briefly.
- Press both remote control buttons simultaneously.
- Channel indication will toggle briefly to confirm.
- Release both buttons

Volume will now turn to zero. Learning cycle is completed and the new code will be memorised. Repeat this procedure if code is not memorised correctly (e.g. due to interference). Code will be retained in case of power failure.

The unit is now ready for use. Fasten the lid with the two supplied screws as shown.

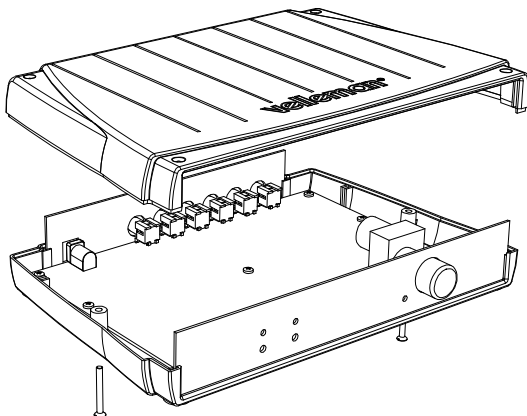

21. Hook-up to your system

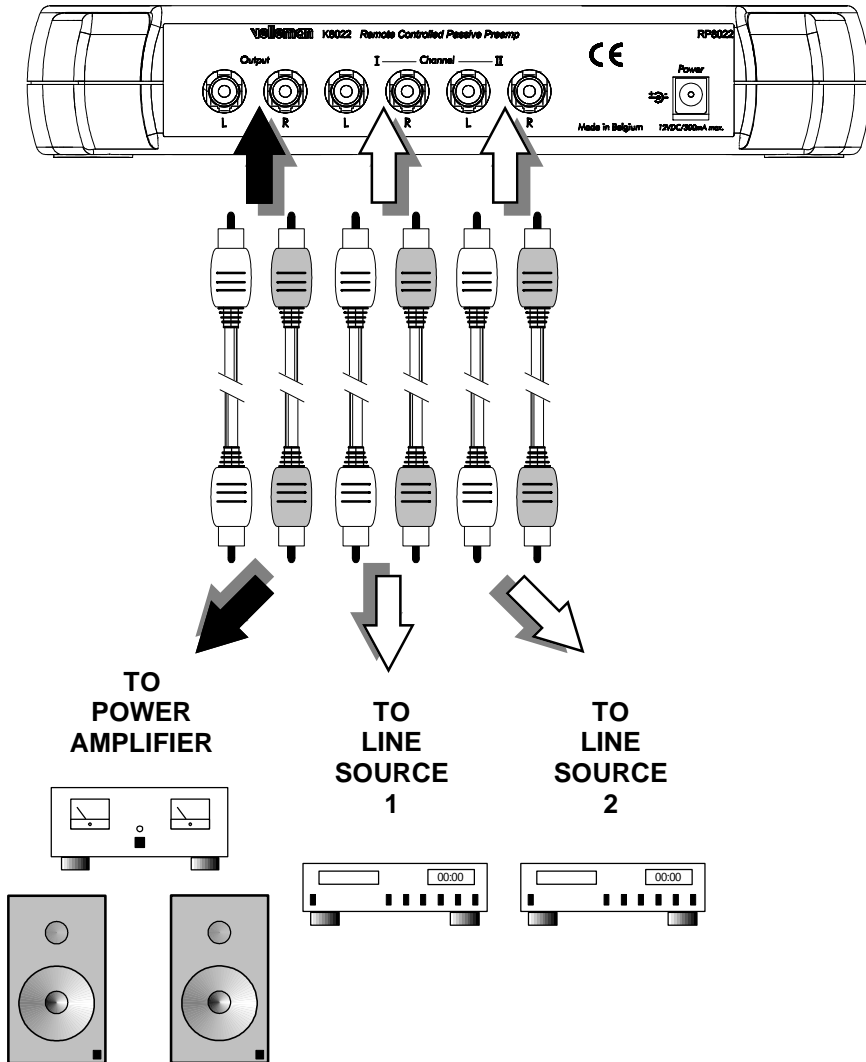

Hook-up the left and right outputs of your K8022 to the left and right inputs of the amplifier.

You can hook up a line-level source (e.g. CD player, MD player, tuner, tape recorder, ...) to each input channel

22. Operation

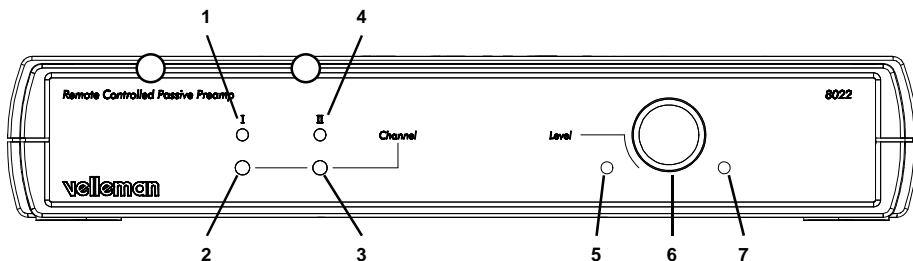

- 1 Channel I indicator
- 2 Channel I selector. Push to select channel I.
- 3 Channel II selector. Push to select channel II.
- 4 Channel II indicator
- 5 'Volume down'-indicator.
Lights when 'volume down' is pressed on remote control.
- 6 Volume control. Turn clockwise to increase volume
- 7 'Volume up'-indicator.
Lights when 'volume up' is pressed on remote control.

Remote control :

Affix the supplied sticker to the housing.

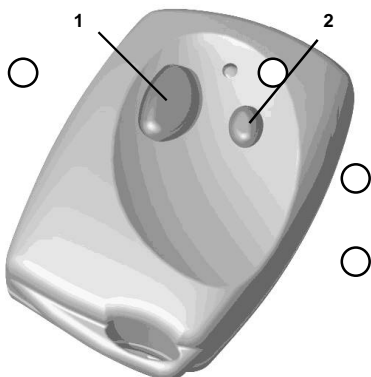

- 1 'Volume down'-pushbutton. Push to reduce volume
- 2 'Volume up'-pushbutton. Push to increase volume

Press both buttons simultaneously to toggle between CH I and CHII

23. PCB layout

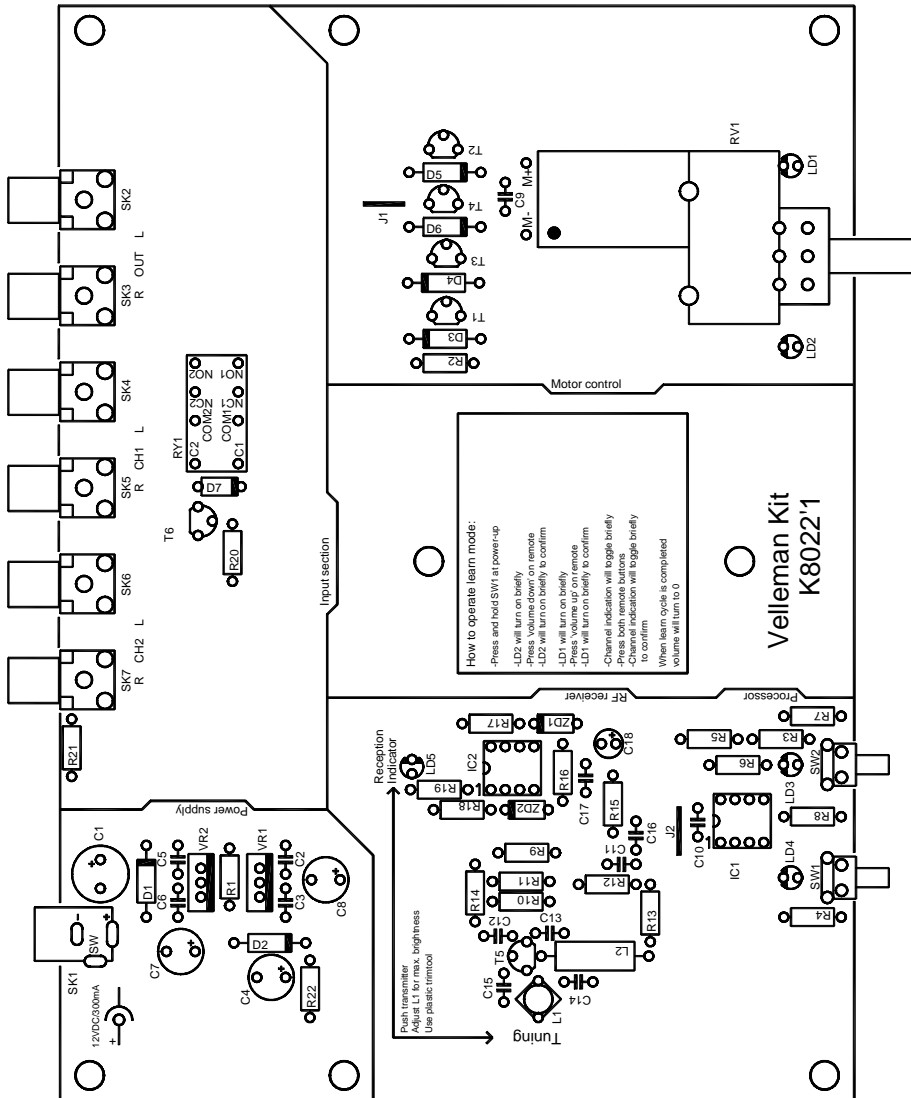

24. Diagram

*Values are subject to changes in the interest of product improvement
Refer to partlist and/or added notes for actual values and references

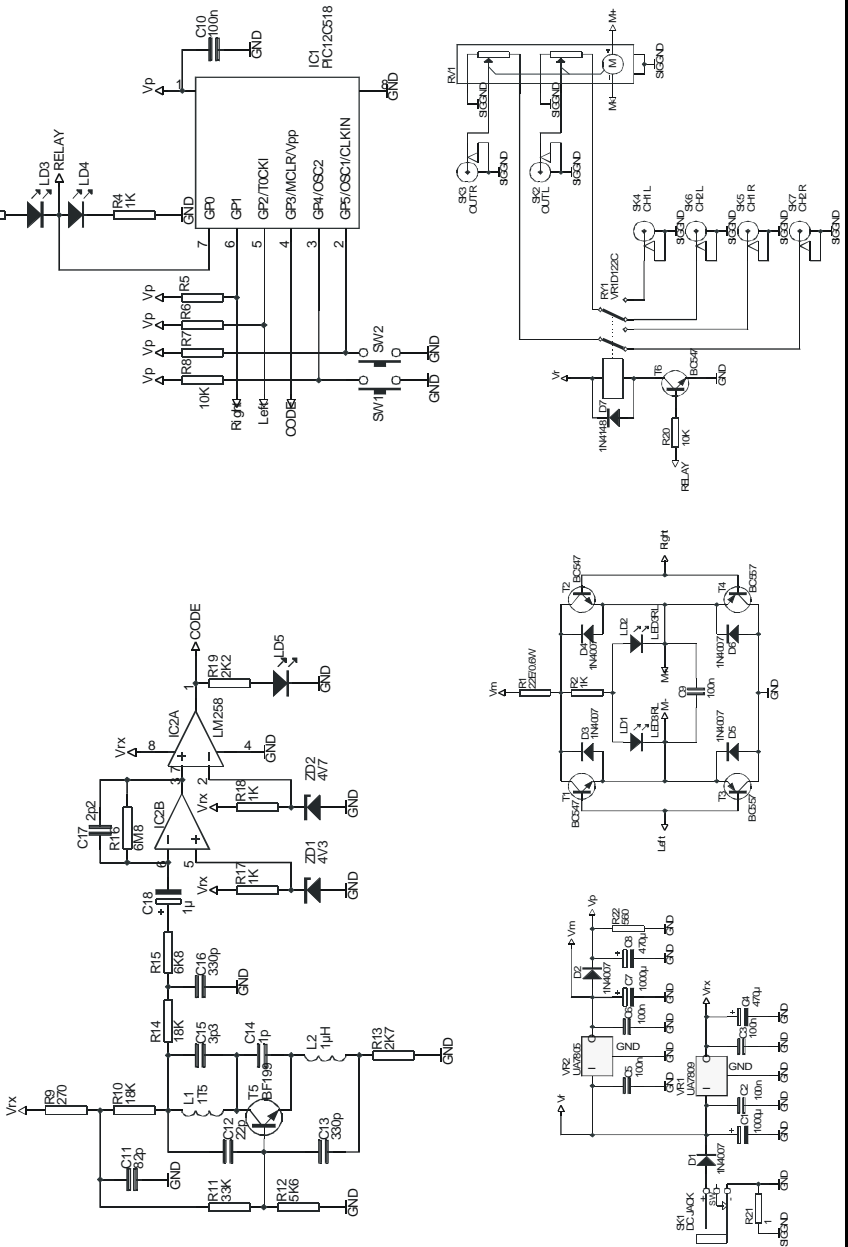

VELLEMAN COMPONENTS NV
Legen Heirweg 33
9890 Gavere
Belgium Europe
Info & support: www.velleman.be

Modifications and typographical errors reserved
© Velleman Components NV
H8022IP - 2002 - ED2